



DC INVERTER

AIR TO WATER HEAT PUMP

H series: Only Heating series

AC series: Heating & Cooling series

HC series: Multifunctional Heating Cooling & Hot water

Technical Manual

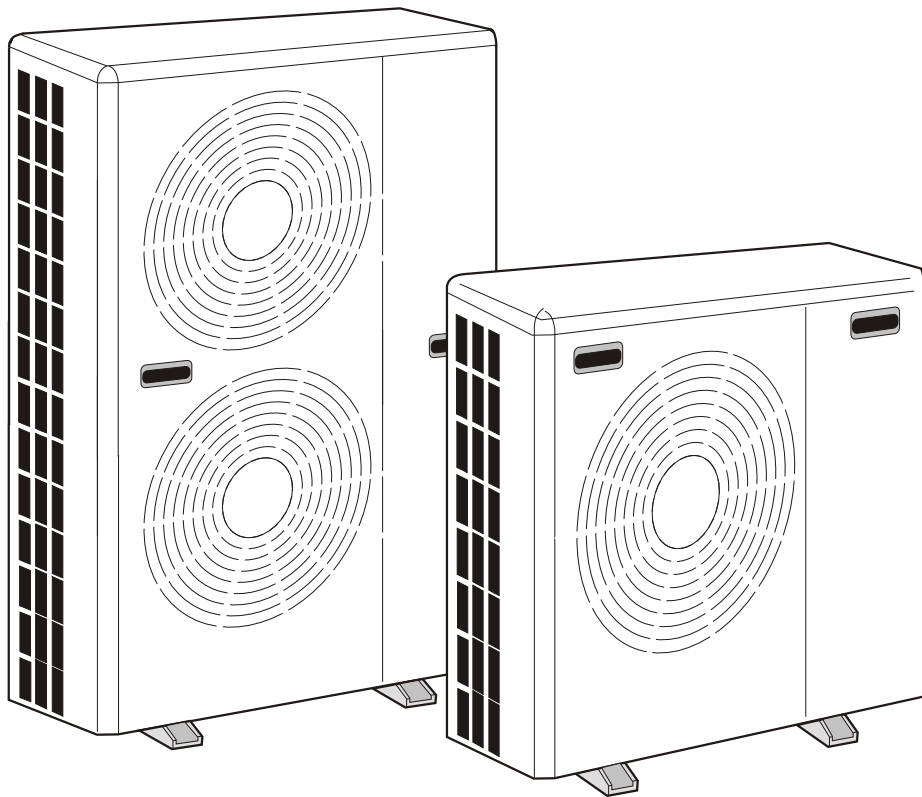

Content

Safety precautions.....	2
Components.....	3
Unit dimension	4
Specification.....	5
Wire controller.....	6
Unit operation.....	7
Error code.....	13
Operation range.....	14
Heating&cooling performance.....	15
Installation.....	19
Installation position.....	23
Electrical connection.....	24
Test run.....	26

Safety Precautions

Note!

It is required to read the Safety precautions in detail before operation. The precautions listed below are all-important for safety, please obey without fail.

General

- ❗ Make sure that the fixed ground wire in the building is securely connected to earth.
- ❗ Wiring tasks should be carried out by qualified electricians only, in addition, they should check the safety conditions of power utilization, for example, check if the line capacity is adequate, and check if the power cable is damaged.
- ❗ Users must not install, repair or relocate the unit.
Improper treatment might lead to the accidents e.g. personal injury caused by fire, electrical shock or unit's falling-off, and water leakage in the machine. Please contact professional repair and service department of local dealer.
- ❗ The unit shall not be installed at a spot with potential hazard of leakage of inflammable gas.
In case the leaked gas is congregated around the machine, there might be the risk of explosion.
- ❗ Make sure that the foundation of installation is stable.
If the foundation is unstable, the outdoor unit may drop and cause a casualty accident. so this must be validated carefully.
- ❗ Make sure that the electric leakage protection switch is fixed.
If no electric leakage protection switch is fitted at the beginning of the electric supply, it maybe cause electric shocks or fires.
- ❗ If any abnormality occurs in the unit (such as burned taste inside the unit), cut off the power supply immediately, and contact professional repair and service department of local dealer.
- ❗ Please observe the follow items when cleaning the unit.
Before cleaning, shut off the electric supply of the unit firstly to avoid injuries caused by fan in operation.
Do not rinse the unit by water because the rinsed unit may cause electric shock.
- ❗ Make sure to shut off the electric supply before maintaining the unit.
- ❗ Please do not insert fingers or sticks into air outlet or air inlet.

Transport and storage

- ❗ The machine must be transported and stored vertically.

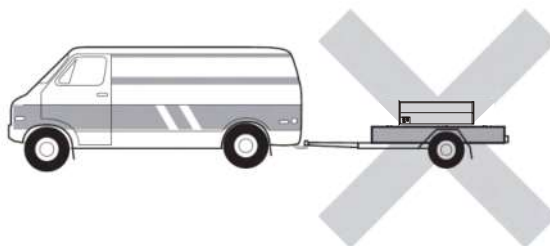

Components

AH-6,AH-8,AH-11,AH-15DC

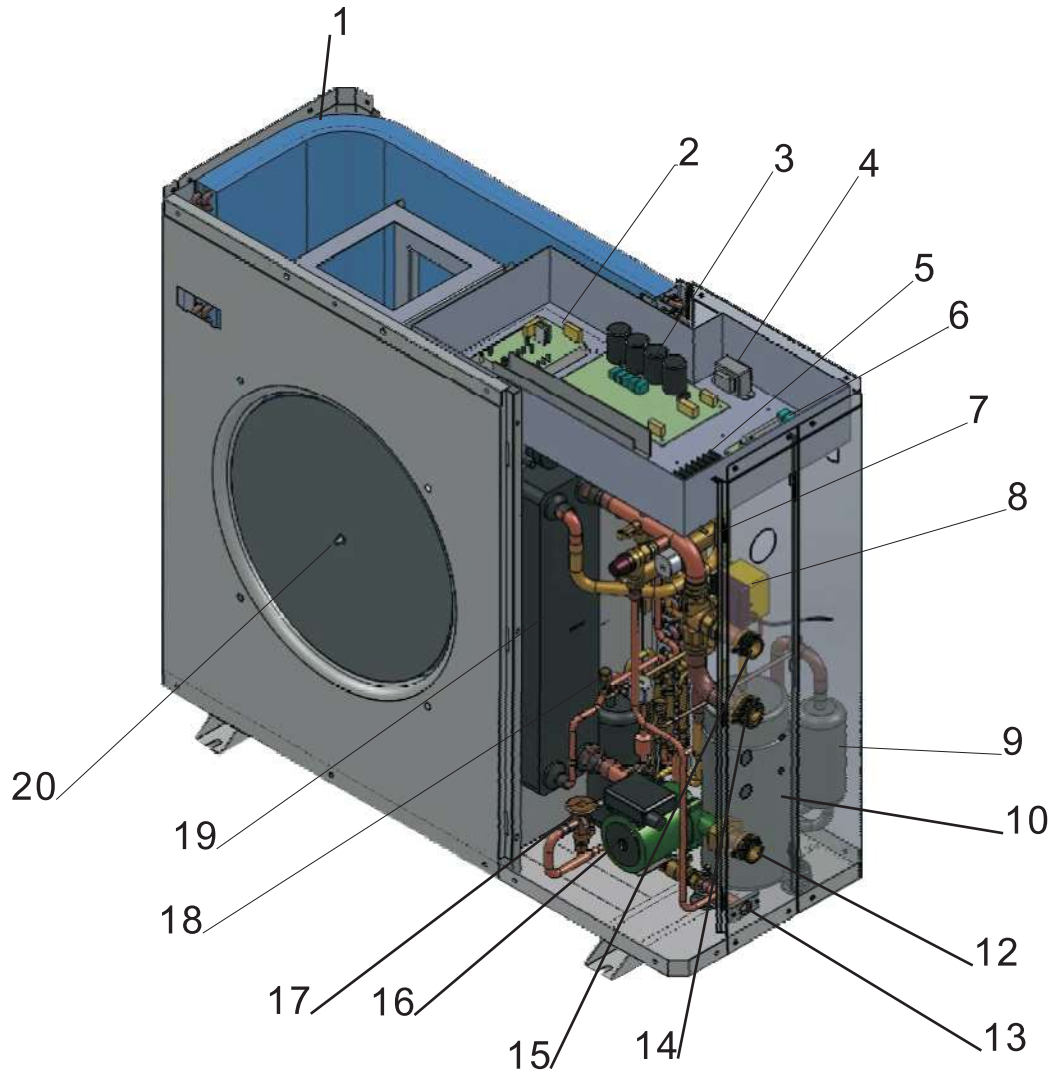

Position

Component

1	Evaporator
2	IPM Module
3	Main control board
4	Transformer
5	Terminal blocks
6	Water system control board
7	4 way valve
8	3 way valve
9	Gas liquid isolator
10	Compressor

Position

Component

12	Water inlet
13	Drain
14	AC Outlet
15	DHW Outlet
16	Water circulation pump(Optional)
17	Thermal Expansion Valve
18	Needle valve
19	Plate heat exchanger
20	Fan and fan motor

AH-6DC,AH-8DC,AH-11DC,AH-15DC

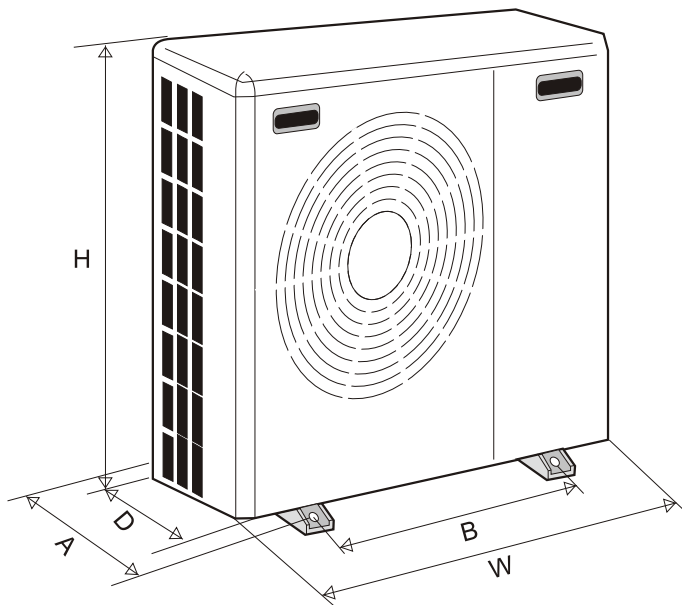

Model	AH-6,AH-8	AH-11	AH-15DC
W	1091	1091	1091
D	400	400	400
H	780	880	980
A	412	412	412
B	810	810	810

DC inverter Air to Water Heat Pumps Specification

Models	Air temp/outlet water temp	AH-6AC-410DC	AH-8AC-410DC	AH-11AC-410DC	AH-15AC-410DC	AH-17AC-410DC
Heating capacity/Power input (KW)	at A20/W35°C	7.2/1.45	9.7/1.96	13.2/2.69	18/3.65	21/4.3
	at A7/W35°C	5.8/1.4	7.8/1.9	10.6/2.6	14.6/3.5	17.3/4.2
	at A7/W45°C	5.50/1.65	7.50/2.23	9.45/2.85	13.1/3.86	15.5/4.6
	at A2/W35°C	4.83/1.40	7.24/2.15	9.02/2.57	12.7/3.6	14.7/4.2
	at A2/W45°C	4.8/1.6	7.1/2.31	8.8/2.86	11.8/3.85	14.2/4.58
Max.currentt (A)		9.5	12	15	20	25
Electric supply		230V/50-60Hz				
Max.water temperature (°C)		60				
Running temperature range (°C)		-25 ~ 43				
Refrigerant circuit	Refrigerant	R410a				
	DC Inverter compres	Rotary	Twin Rotary	Twin Rotary	Scroll	
	Heat exchange	Copper and Aluminum Fin				
	Air flow (m ³ /h)	2100	2400	2900	4000	5800
Water circuit	Heat exchanger	Plate heat exchanger				
	In/Out pipe	DN20(3/4")	DN25(1")	DN25(1")		
	Water flow (m3/h)	≥0.8	≥1.2	≥1.8	≥2	≥2.5
	permitted pressure	≤0.8MPa				
Unit dimensions WxHxD (mm)	855x635x335	850x850x310	880*1090*400	1016*1090*462	1272*1090*462	
Pacage dimensions WxHxD (mm)	985x745x410	985x980x410	1035**1190*508	1170*1180*530	1430*1180*530	
Net weight (Kg)	45	64	95	140	178	
Gross weight (Kg)	50	75	115	150	190	
Noise level (dB(A))	46	49	50	52	52	

Notes:

1. The above list all the data during different condition. For example: AT A7°C/W35°C , means the test condition is air temp is 7 °C, The Outlet water temp is 35°C. This is the EN14511 standard.

2. The above model is only heating or cooling function which can be used for heat pump central room heating or cooling(with 1 water outlets and 1 water inlets)

Multifunctional model with Heating Cooling and Domestic hot water in one solution is optional

3. Model No illustration

AH(P)-14-410 Normal domestic hot water model, only heating

AH(P)-14AC-410..... Heating Cooling model with heating and cooling

AH(P)-14-HC-410... Multifunctional model with heating cooling and domestic hot water function in one solution(with inner solenoid 3 way valve).

with "P" means with circulation water pump, without "P" means without circulation water pump.

CONTROL PANEL

1. Wire controller

Wire controller contains a LCD and 6 operational keys (as show below). It can keep memory when power off and be a timer.

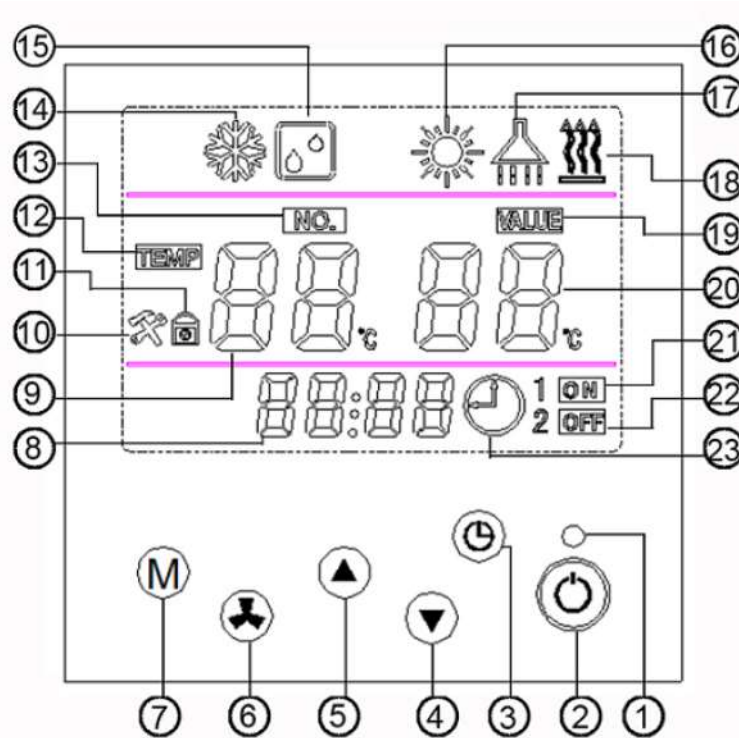

2. Key functions

- (1) Double-colored indicator light: when standby, blue light on; when compressor worked, red light on; when breakdown happened, red light on. For more details, please check fault code sheet.
- (2) Key “on/off” : power on /power off.
- (3) Key “time adjusting”: adjust clock or set time.
- (4) Key “down”: it’s a combined key to decrease numerical value, continuous press, then continuous decrease; short press, then decrease by 1.
- (5) Key “up”: it’s a combined key also, but opposite to down key. Continuous press, then continuous increase; short press, then increase by 1.
- (6) Key “confirm”: confirm previous operations
- (7) Key “mode”: operational mode’s switch. It’s a combined key also.

3. Icon Meaning

NO.	Icon meaning	NO.	Icon meaning	NO.	Icon meaning
8	Clock display	9	Returned AC Temp.	10	Maintain icon
11	Lock icon	12	Temperature icon (Reserved)	13	Parameter number icon
14	AC Cooling icon	15	Sterilization icon	16	AC heating icon
17	Sanitary hot water icon	18	Water/ground source display	19	Parameter icon
20	Domestic Hot Water temp	21	Timer on icon	22	Timer off icon
20	Sterilization days display	21	Sterilization on display	22	Sterilization off display
23	Clock icon				

UNIT OPERATION

1. Switch the unit on and off

To start the unit, press and hold the On/Off key for one second

To stop the unit, press and hold the On/Off key for one second

2. Mode switch (5 modes in total)

A. Under mode standby or On, press the M key repeatedly, the following icons will flash by recycling.

AC cooling -> AC heating -> DHW(Domestic hot water)-> AC cooling + DHW ->AC heating + DHW

When selected a mode, press  button to confirm, then the icon will be solid, heat pump will perform as selected.

B. When in mode AC cooling +DHW or AC heating & DHW, DHW heating will be the priority.

C. When select DHW mode, only hot water system working, no air conditioner working.





D. When select air conditioner mode, only air conditioner system working, no sanitary hot water system working.

E. Sterilization is independent and auto-operated. You can change parameter according to need.

















3. Procedures of setting parameter change

A. When in settled mode, the unit will operate in accordance with the factory default temperature or last modified temperature.

B. Modification method for settled temperature

In the on / standby mode, press key M and  for 3 seconds, the current operating mode light will flash; by press the M key, you can switch modes in the following order: Cooling / heating / hot water / sterilization; by pressing key  or  to setting value, press key  to confirm, then exit and save current changes; if didn't press key  to confirm, it will exit the parameter modification automatically 15 seconds later. Previous Changes will not be saved.















Detailed settings as follows:

NO.	Meaning	Settled temperature range	Default temperature	operation for modify settled parameters
1	AC cooling returned water temp	10°C ~ 25°C	12°C	M+  → M →  or  → 
2	AC Heating returned water temp	10°C ~ 55°C	45°C	M+  → M →  or  → 
3	sanitary hot water heating	10°C ~ 60°C (AU)	50°C	M+  → M →  or  → 
4	Legionella Anti-bacteria	60°C ~ 70°C	65°C	M+  → M →  or  → 





UNIT OPERATION

C. Time setting procedure for health sterilization

Only in sanitary hot water mode, health sterilization will work. If sanitary hot water mode off, health sterilization will fail to work.

In on or standby mode, first, press key M and  for 3 seconds, second, press key M, 15 icon appears, then press the  or  to set sterilization temperature, press key  to confirm, the number of days will flash and show the original or default value 7 (that means 7 days), press key  or  to increase or decrease the number of days at predetermined intervals, the minimum of 7 days, maximum of no more than 99 days, after that, press key  to confirm. At this time, "ON" character appears, "hour" appears and flashes, show the original setting or the default value (default value 01 means it will start at 1:00 am), followed by press key  or  to modify (0-23), after that, press key  to confirm, then the new time start running. "ON" character disappears, "OFF" character appears, "minute" value flashes and shows the original or default value (default value is 10), followed by press key  or  to change (minimum is 10, maximum no more than 99), after that press key  to confirm and exit change mode. If didn't press key  to confirm, machine will exit change mode automatically after 15 seconds. But settings did right now will become invalid.

4. Time adjustment

Press key , time "hour" value will flash, then press key  or , the value will increase or decrease. Press key and keep, the value will increase or decrease constantly as you want. After Settle down, please press key  to confirm, then exit from time adjusting mode.





5. Time setting

You can set one time to start and one time to off. And select one time working or cyclic working.

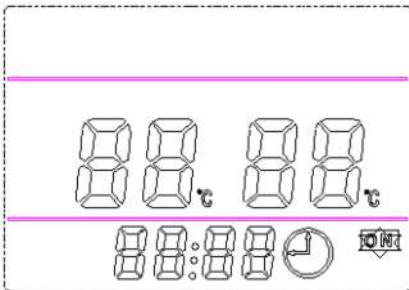
A. settled time on method:



(1) Press  for 3 seconds and come to time setting,  will flash as show below.

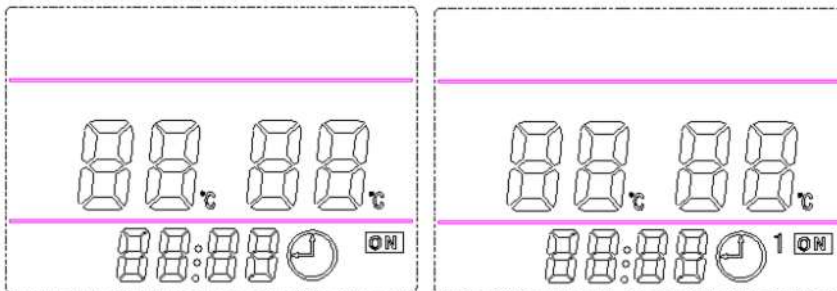

(2) Press key  or  to modify time value, and press  to confirm. This setting only valid for one time. If you want time setting to work cyclic, please press key  after time setting, then press key  to confirm.



B. Timing off method are the same as timing on method.

C. Please press key  for 3 seconds and come to timing mode, press  to cancel time setting.

6. Parameter Checking and setting

Please press key M+▲ for 3 seconds and enter to parameter setting mode as show below.

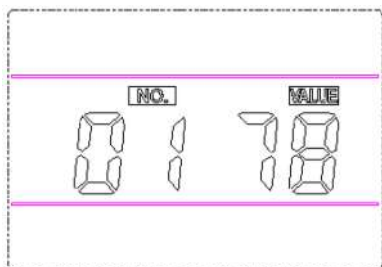

“01”is parameter code,“78”is parameter values. Other items’ parameters meaning are the same with above picture showed.

Parameter list:

NO.	Name	range/meaning	default	status	remark
00	power off auto restart	0: not restart; 1: Auto restart	1	check/set	
01	hot water temp return differential	2~15℃, minus return differential	2℃	check/set	
02	air conditioning return differential	2~15℃, minus return differential	2℃	check/set	
03	defrost start temp.	-20~5℃	0℃	check/set	
04	water source anti-freeze temp.	-20~5℃	2℃	check/set	
05	antifreeze exist temp.	-5℃~5℃	5℃	check/set	
06	defrost exist temp.	10~35℃	30℃	check/set	
08	Interval between 2 defrosts	15~99 mins	35	check/set	
09	ambient temp of DHW backup electrical heater start	-20~20℃	0℃	check/set	
10	ambient temp of AC backup electrical heater start	-20~20℃	0℃	check/set	
11	reserved				
12	Exhaust gas protection temp.	100~129℃/2	57	check/set	
13	reserved				
14	function parameter	0: G3 is seasonal switch valve; 1: G3 is solar pre-heat valve;	0	check/set	
19	adjust fixed running rate	0~100 HZ	50HZ	check/set	
20	Run set rate	1: practical running; 0: manual rate running	1	check/set	

Note:

Usage of 14. Function parameter: (As per solar application 1)

when this parameter is 1, when air conditioning heating run, it will compare solar water tank temp with air conditioning returned water temp, when solar water tank temp is 5 or more degree higher than air conditioning returned temp, the 3-way valve G3 electricity supply will be on; when solar water tank temp - air conditioning returned temp is less than 2 centigrade, G3 electricity supply will be off. This function is to use solar to preheat for room heating and DHW tank water.

When this parameter is 0, G3 is seasonal switch valve, when the heat pump is working for heating, G3 is on, when heat pump is working for cooling, G3 is off.

Normally use one 3-way valve with 3 wires. 2 wires are always connected with electricity supply and 1 signal wire is connected with heat pump G3 terminal port to enable function.

7. Machine operational status Checking

Press both key M and ▼ for 3 seconds, then entered machine status form. Show as below.

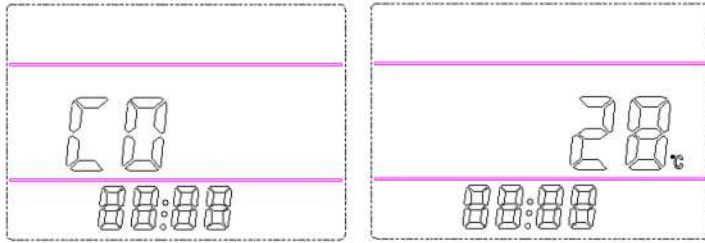

“C0” is part or parameter NO. , “28” stands for parameter. Parameter 0 means system on, 1 means system off. For more detail, please check form below.

Press M+ ▼ for 3 seconds to search and check parameters .

NO.	Name	range/meaning	status
00	Outdoor pipe temp.	-9~97℃	check
01	Exhaust gas temp./on and off	inverter: -9~97℃ on/off: 0 (off); 1 (on)	check
02	Ambient temp.	-9~97℃	check
03	AC inlet water temp.	-9~97℃	check
04	water source inlet water temp.	-9~97℃	check
05	water source outlet water temp.	-9~97℃	check
06	Switch input status	0 (heating&cooling) 1 (heating only)	check
07	Switch input status	0 (air source); 1 (water source)	check
08	Switch input status	0 (DHW invalid); 1 (DHW valid)	check
09	Switch input status	0 (G1 valid); 1 (G1 invalid)	check
10	high pressure swithc status	0 (off); 1 (on)	check
11	overcurrent protect switch status	0 (off); 1 (on)	check
12	low pressure swithc status	0 (off); 1 (on)	check
13	inside water flow switch	0 (off); 1 (on)	check
14	outside water flow switch	0 (off); 1 (on)	check
15	The 2nd high pressure switch status	0 (off); 1 (on)	check
16	defrost		check
17	air conditioning antifreeze		check
18	System antifreeze		check
19	Compressor status	Inverter model: show running frequency, On/off model: show 0 for off or 100 for on	check
20	Outdoor fan motor	1: run; 0: stop	check
21	crankcase heater	1: run; 0: stop	check
22	4-way valve	1: run; 0: stop	check
23	Bypass valve	1: run; 0: stop	check
24	solenoid valve 1	1: run; 0: stop	check
25	solenoid valve 2	1: run; 0: stop	check
26	solenoid valve 3	1: run; 0: stop	check
27	Electrical heater 1	1: run; 0: stop	check
28	Electrical heater 2	1: run; 0: stop	check

29	C4 water pump	1: run; 0: stop	check
30	C5 water pump	1: run; 0: stop	check
31	C6 water pump	1: run; 0: stop	check
32	functional parameter	0-99 (accumulated days from last legionella until now)	check
33	Target cooling temp.		check
34	Target heating temp		check
35	Target hot water temp		check
36	Target legionella temp		check
37	outdoor unit module temp.	-9~97℃	check
38	Outdoor unit returned gas temp.	-9~97℃	check
39	Internal pipe temp.	-9~97℃	check

8. Displays for different kinds of modes

(1) tritherma water/ground source heat pumps icons

(2) air source heat pumps icons:

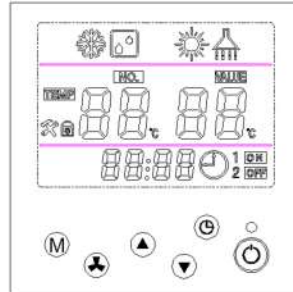
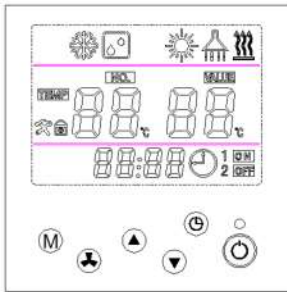

(3) powered off display

(water source heat pump has water source icon. If it has timer on/off setting, there is timer icon to indicate.)

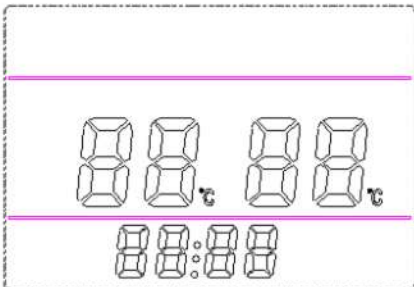

(4) AC cooling display

(5) heating display

(water source heat pump has water source icon. If it has timer on/off setting, there is timer icon to indicate.)

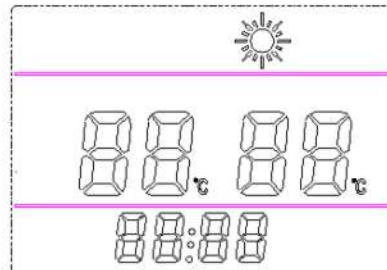
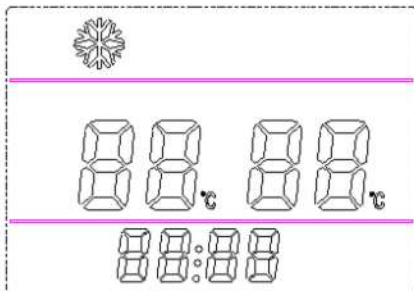

(6) sanitary hot water display

(water source heat pump has water source Icon. If it has timer on/off setting, there is timer icon to indicate.)

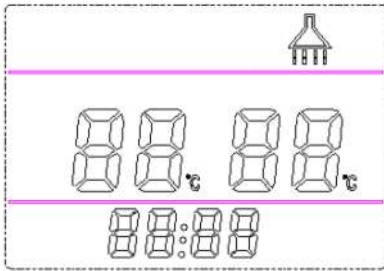

(7) AC cooling and sanitary hot water display

(8) AC heating and sanitary hot water display

(water source heat pump has water source Icon. If it has timer on/off setting, there is timer icon to indicate.)

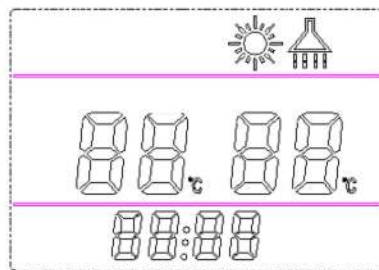
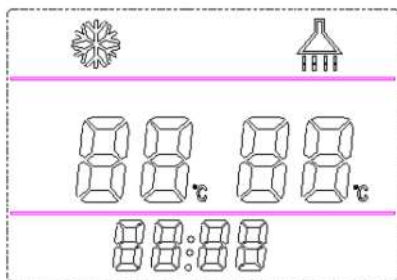

9. way of communication

Non-polarity double wire, maximum running length is 100 meters and point to point connected.
Back view of wired controller showed below.

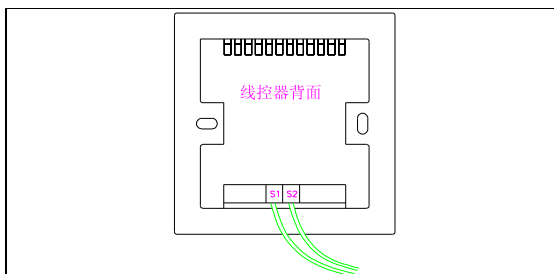

10. Function Selection Switch: SW4

(after change, need be repowered to enable the change)

SW4-8	OFF: cooling valid; ON: cooling invalid
SW4-7	OFF: heating valid; ON: heating invalid
SW4-6	OFF: DHW valid; ON: DHW invalid
SW4-5	OFF: G1 valid; ON: G1 invalid
SW4-4	OFF: inverter outdoor model; ON: on/off outdoor model
SW4-3	reserved
SW4-2	reserved
SW4-1	OFF: geothermal; ON: air source

ERROR CODE

When machine has error, the control will show "P" or "E" at AC temp location and show error code at DHW temp location, press key ▼ to search more error codes happened at the same time. Please see table below for error code meaning.

Code display like EX or Px, eg: E2、 P5

Code	Error meaning	light	remark
E1	compressor overheat or discharge gas high temp protect	Red and shining	Outdoor unit
E2	Outdoor ambient temp. sensor error	Red and shining	Outdoor unit
E3	Pipe temp. sensor error	Red and shining	Outdoor unit
E4	AC returned water temp. sensor error	Red and shining	AC, stop compressor
E5	AC output water temp. sensor error	Red and shining	AC, stop compressor
E6	Hot water temp. sensor error	Red and shining	Hot water, stop compressor
E7	Solar water temp. sensor error	normal	Compressor run
E8	coil hot water protect	Red and shining	Outdoor unit
E9	system antifreeze twice	Red and shining	Stop compressor
EA	DHW antifreeze twice	Red and shining	Stop compressor
F1	Voltage protect	Red and shining	Only for Inverter outdoor unit
F2	Machine type mismatching	Red and shining	Only for Inverter outdoor unit
F3	Compressor stopped abnormally	Red and shining	Only for Inverter outdoor unit
F4	outdoor module radiator transducer error	Red and shining	Only for Inverter outdoor unit
F5	Outdoor unit current transducer error	Red and shining	Only for Inverter outdoor unit
F6	IPM or module control board error	Red and shining	Only for Inverter outdoor unit
F7	Compressor fail to start	Red and shining	Only for Inverter outdoor unit
F8	Outdoor unit overcurrent	Red and shining	Only for Inverter outdoor unit
F9	Exhausted gas temp. transducer error	Red and shining	Only for Inverter outdoor unit
FA	Outdoor module overheat or over-current	Red and shining	Only for Inverter outdoor unit
FB	Outdoor coil overheat	Red and shining	Only for Inverter outdoor unit
P1	high pressure protect	Red and shining	outdoor unit
P2	Low pressure protect	Red and shining	Outdoor unit
P3	Overheat protect	Red and shining	Outdoor unit
P4	Overcurrent protect	Red and shining	Outdoor unit
P5	indoor unit water flow error	Red and shining	Stop compressor
P6	outdoor unit water flow error	Red and shining	Outdoor unit
P7	phase loss	Red and shining	Outdoor unit
P8	misphase	Red and shining	Outdoor unit
P9	Communicate error	Red and shining	Outdoor unit

Cooling Mode

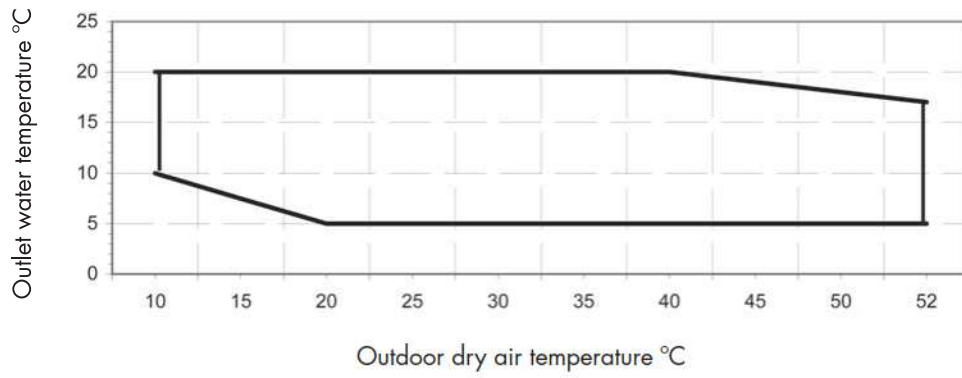

Heating Mode

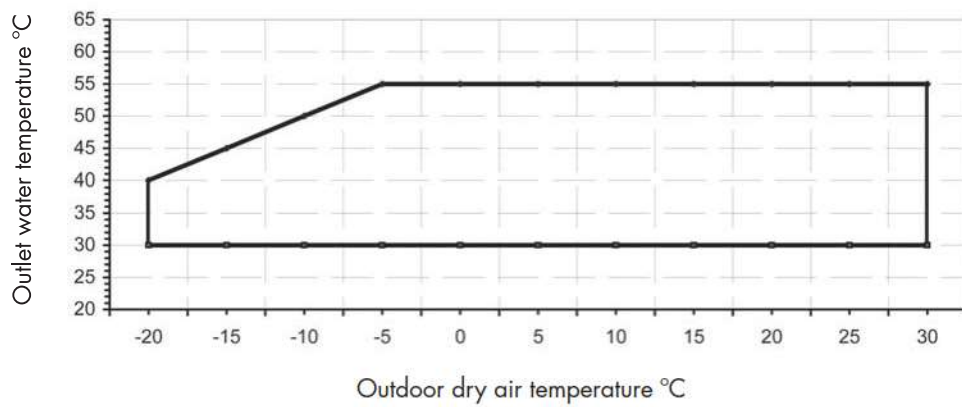

D.H.W Mode

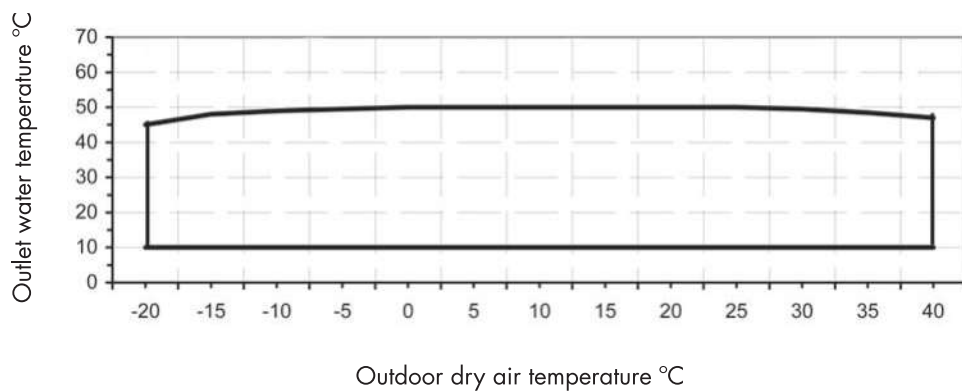

HEATING & COOLING PERFORMANCE

AH-6AC-410DC Nominal Water Flow Rate 1 ton/hour

Water Outlet Temperature °C		Outdoor air wet bulb temperature °C											
		-20	-15	-10	-5	0	2	6	10	15	18	20	25
30	Capacity	2.84	3.3	3.84	4.46	5.19	5.25	6.03	6.45	6.9	7.11	7.38	7.68
	Power Input	1.17	1.21	1.25	1.3	1.34	1.35	1.39	1.41	1.41	1.42	1.42	1.45
	COP	2.42	2.72	3.06	3.44	3.87	3.88	4.35	4.59	4.9	5	5.18	5.28
35	Capacity	2.73	3.17	3.69	4.29	4.99	5.05	5.8	6.21	6.64	6.84	7.1	7.39
	Power Input	1.18	1.22	1.26	1.31	1.36	1.37	1.4	1.42	1.42	1.44	1.44	1.47
	COP	2.31	2.6	2.92	3.28	3.68	3.69	4.14	4.37	4.67	4.76	4.94	5.02
40	Capacity	2.65	3.08	3.58	4.16	4.84	4.9	5.63	6.02	6.44	6.63	6.89	7.16
	Power Input	1.27	1.32	1.36	1.41	1.46	1.47	1.51	1.53	1.53	1.55	1.55	1.58
	COP	2.08	2.34	2.63	2.95	3.32	3.33	3.73	3.94	4.21	4.29	4.45	4.53
45	Capacity	2.59	3.01	3.5	4.07	4.73	4.79	5.5	5.89	6.3	6.49	6.74	7.01
	Power Input	1.4	1.45	1.5	1.55	1.6	1.61	1.65	1.68	1.68	1.69	1.7	1.74
	COP	1.85	2.08	2.34	2.63	2.96	2.97	3.33	3.51	3.75	3.83	3.97	4.04
50	Capacity		2.86	3.33	3.87	4.5	4.55	5.23	5.6	5.99	6.17	6.41	6.66
	Power Input		1.59	1.65	1.7	1.76	1.78	1.83	1.85	1.85	1.88	1.87	1.92
	COP		1.8	2.02	2.27	2.55	2.55	2.86	3.02	3.23	3.29	3.42	3.47
55	Capacity			3.16	3.67	4.27	4.32	4.97	5.32	5.69	5.86	6.09	6.33
	Power Input			1.82	1.88	1.95	1.97	2.02	2.05	2.05	2.06	2.07	2.11
	COP			1.74	1.95	2.19	2.19	2.46	2.6	2.78	2.84	2.94	3

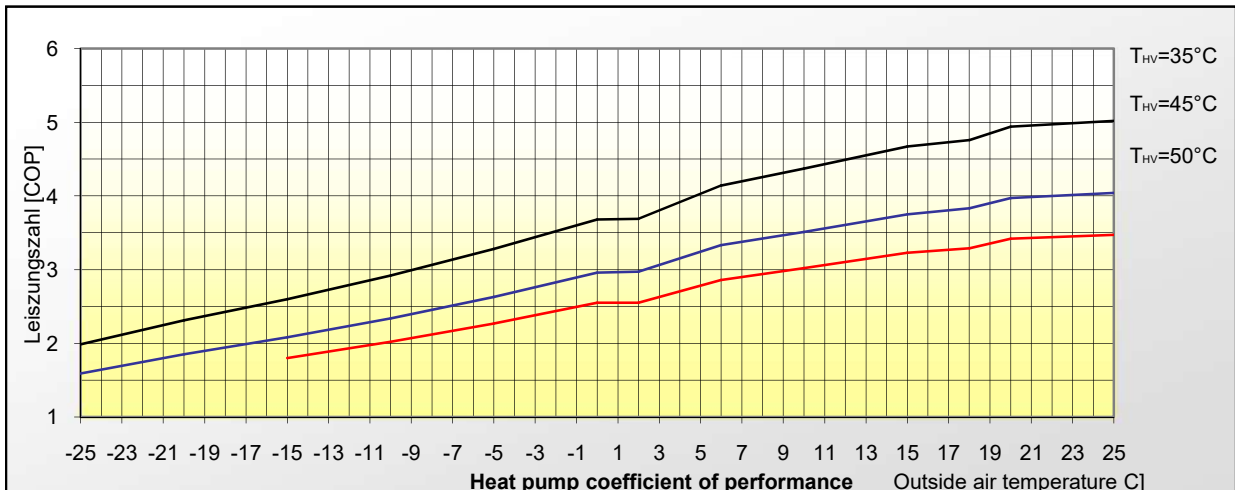
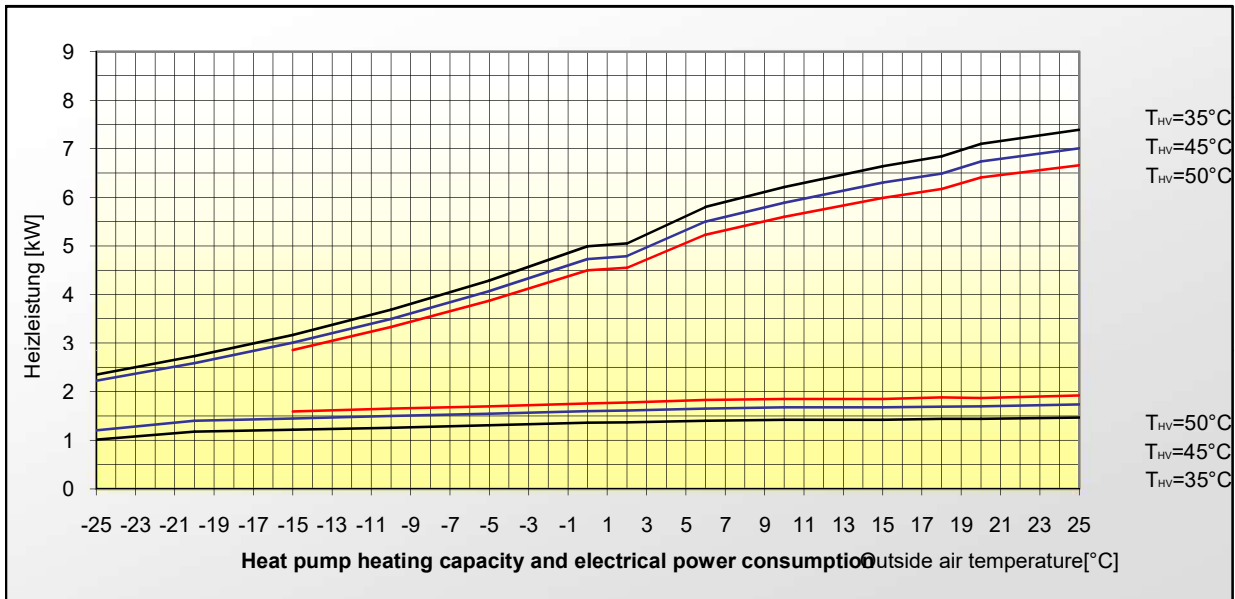

HEATING&COOLING PERFORMANCE

AH-8AC-410DC Nominal Water Flow Rate 1.5 ton/hour

Water Outlet Temperature °C		Outdoor air wet bulb temperature °C											
		-20	-15	-10	-5	0	2	6	10	15	18	20	25
30	Capacity	3.81	4.43	5.15	5.99	6.97	7.06	8.11	8.68	9.29	9.57	9.94	10.34
	Power Input	1.58	1.63	1.69	1.75	1.82	1.83	1.88	1.9	1.91	1.93	1.93	1.97
	COP	2.41	2.71	3.04	3.42	3.84	3.85	4.32	4.56	4.87	4.97	5.15	5.24
35	Capacity	3.67	4.27	4.96	5.77	6.71	6.79	7.8	8.35	8.93	9.2	9.56	9.94
	Power Input	1.6	1.66	1.71	1.77	1.83	1.85	1.9	1.92	1.92	1.95	1.95	1.99
	COP	2.3	2.58	2.9	3.26	3.66	3.67	4.11	4.34	4.64	4.73	4.91	4.99
40	Capacity	3.57	4.15	4.82	5.6	6.51	6.59	7.57	8.1	8.67	8.93	9.28	9.64
	Power Input	1.73	1.79	1.85	1.91	1.98	2	2.05	2.08	2.08	2.1	2.1	2.15
	COP	2.06	2.32	2.61	2.93	3.29	3.3	3.7	3.9	4.17	4.25	4.41	4.48
45	Capacity	3.53	4.1	4.77	5.55	6.45	6.53	7.5	8.03	8.59	8.85	9.19	9.56
	Power Input	1.88	1.94	2.01	2.09	2.16	2.18	2.23	2.27	2.27	2.29	2.3	2.35
	COP	1.88	2.11	2.37	2.66	2.99	3	3.36	3.54	3.78	3.86	4	4.07
50	Capacity		3.9	4.53	5.27	6.13	6.2	7.13	7.63	8.16	8.4	8.73	9.07
	Power Input		2.14	2.22	2.3	2.39	2.4	2.47	2.5	2.5	2.52	2.53	2.58
	COP		1.82	2.04	2.29	2.57	2.58	2.89	3.05	3.26	3.33	3.45	3.51
55	Capacity			4.31	5.01	5.82	5.89	6.77	7.24	7.75	7.98	8.29	8.62
	Power Input			2.45	2.53	2.62	2.65	2.72	2.75	2.76	2.78	2.79	2.84
	COP			1.76	1.98	2.22	2.22	2.49	2.63	2.81	2.87	2.97	3.03

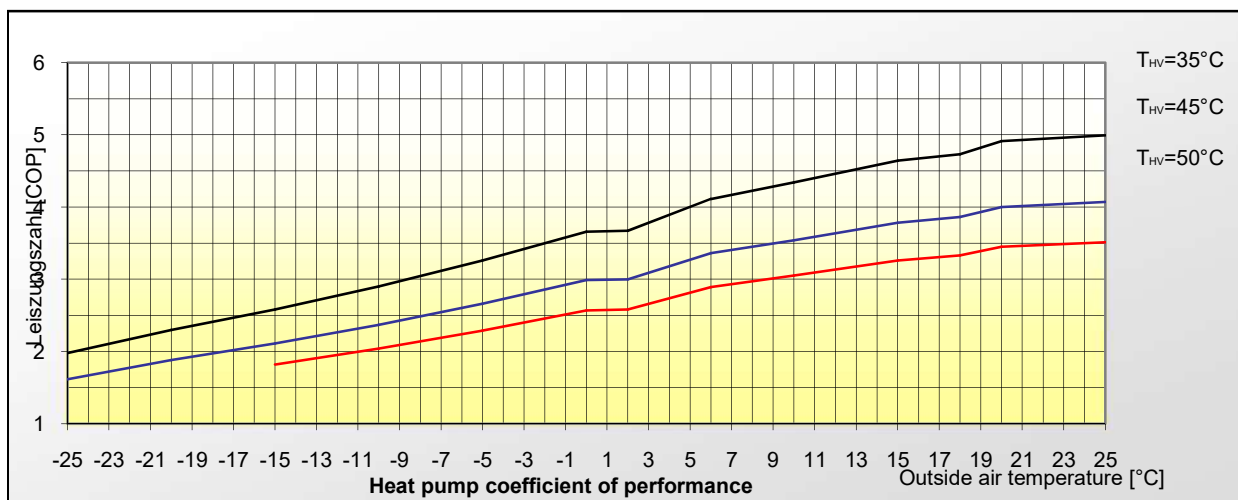
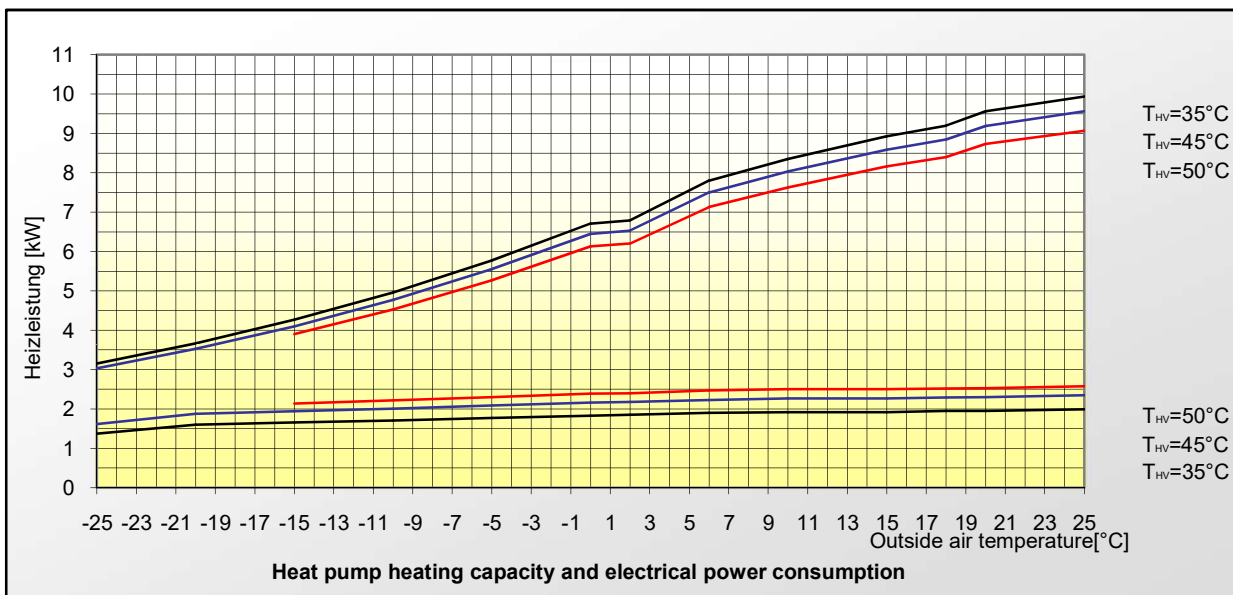

HEATING&COOLING PERFORMANCE

AH-11AC-410DC Nominal Water Flow Rate 1.9 ton/hour

Water Outlet Temperature °C		Outdoor air wet bulb temperature °C											
		-20	-15	-10	-5	0	2	6	10	15	18	20	25
30	Capacity	5.19	6.03	7.01	8.15	9.48	9.59	11.02	11.79	12.62	13	13.5	14.04
	Power Input	2.17	2.24	2.32	2.4	2.49	2.51	2.57	2.61	2.61	2.64	2.64	2.7
	COP	2.39	2.69	3.02	3.39	3.81	3.82	4.28	4.52	4.83	4.93	5.11	5.2
35	Capacity	4.99	5.8	6.74	7.84	9.12	9.22	10.6	11.34	12.13	12.49	12.98	13.49
	Power Input	2.2	2.27	2.35	2.43	2.51	2.53	2.6	2.64	2.64	2.67	2.67	2.73
	COP	2.27	2.55	2.87	3.23	3.63	3.64	4.08	4.3	4.59	4.68	4.86	4.94
40	Capacity	4.83	5.62	6.54	7.6	8.84	8.94	10.28	11	11.77	12.12	12.59	13.09
	Power Input	2.34	2.43	2.53	2.61	2.7	2.73	2.8	2.84	2.85	2.88	2.88	2.95
	COP	2.06	2.31	2.59	2.91	3.27	3.27	3.67	3.87	4.13	4.21	4.37	4.44
45	Capacity	4.45	5.17	6.01	6.99	8.13	8.22	9.45	10.11	10.82	11.14	11.58	12.03
	Power Input	2.41	2.49	2.57	2.66	2.76	2.78	2.85	2.89	2.89	2.92	2.92	2.99
	COP	1.85	2.08	2.34	2.63	2.95	2.96	3.32	3.5	3.74	3.81	3.96	4.02
50	Capacity		4.91	5.71	6.64	7.72	7.81	8.98	9.61	10.28	10.59	11	11.44
	Power Input		2.73	2.83	2.93	3.03	3.06	3.14	3.18	3.18	3.22	3.22	3.3
	COP		1.8	2.02	2.27	2.55	2.55	2.86	3.02	3.23	3.29	3.42	3.47
55	Capacity			5.43	6.31	7.34	7.42	8.53	9.13	9.77	10.06	10.45	10.86
	Power Input			3.12	3.24	3.35	3.39	3.47	3.51	3.51	3.54	3.55	3.62
	COP			1.74	1.95	2.19	2.19	2.46	2.6	2.78	2.84	2.94	3

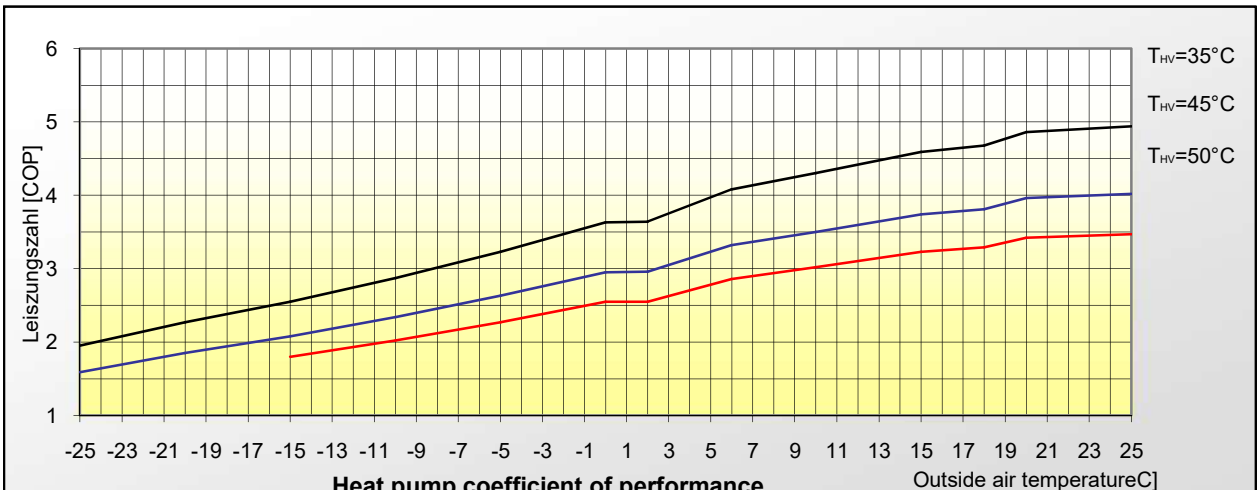
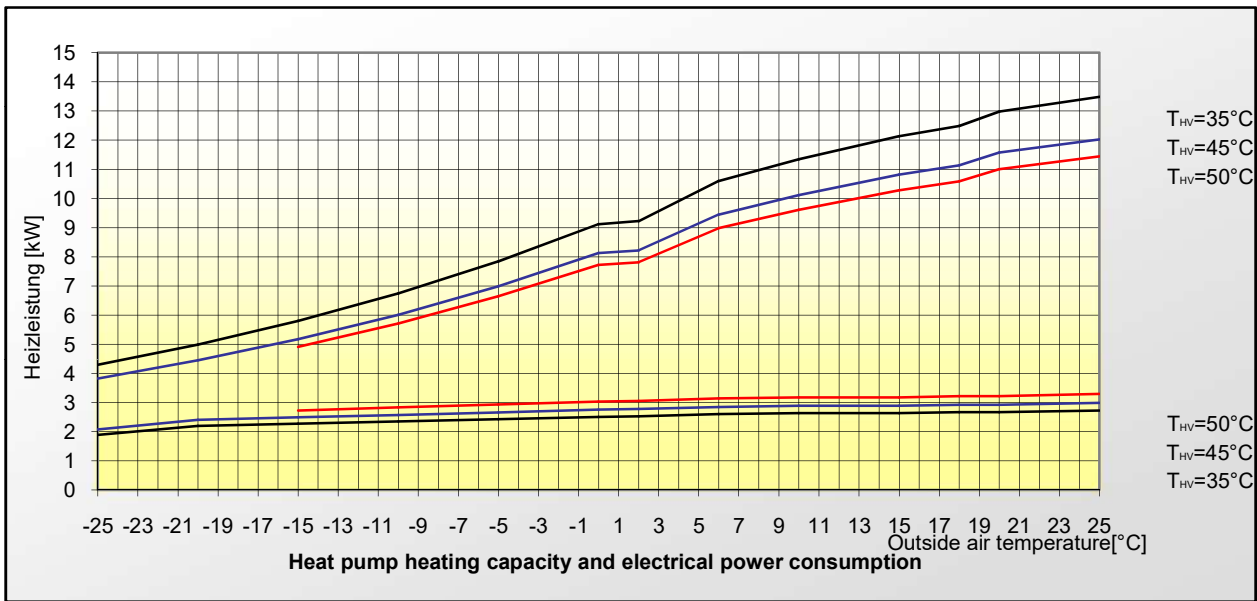

HEATING&COOLING PERFORMANCE

AH-15AC-410DC Nominal Water Flow Rate 2.6 ton/hour

Water Outlet Temperature °C		Outdoor air wet bulb temperature °C											
		-20	-15	-10	-5	0	2	6	10	15	18	20	25
30	Capacity	7.34	8.53	9.92	11.54	13.42	13.57	15.6	16.69	17.86	18.4	19.11	19.87
	Power Input	3.02	3.12	3.23	3.34	3.46	3.49	3.58	3.63	3.64	3.67	3.68	3.76
	COP	2.43	2.73	3.07	3.45	3.88	3.89	4.36	4.6	4.91	5.01	5.19	5.29
35	Capacity	7.05	8.2	9.54	11.09	12.9	13.05	15	16.05	17.17	17.69	18.37	19.11
	Power Input	3.05	3.15	3.27	3.38	3.5	3.53	3.53	3.66	3.67	3.71	3.71	3.8
	COP	2.31	2.6	2.92	3.28	3.69	3.7	4.15	4.38	4.68	4.77	4.95	5.03
40	Capacity	6.85	7.96	9.25	10.76	12.51	12.66	14.55	15.57	16.66	17.16	17.83	18.53
	Power Input	3.29	3.4	3.52	3.64	3.76	3.79	3.89	3.94	3.95	3.99	4	4.08
	COP	2.08	2.34	2.63	2.96	3.33	3.34	3.74	3.95	4.22	4.3	4.46	4.54
45	Capacity	6.49	7.55	8.78	10.21	11.87	12.01	13.8	14.77	15.8	16.27	16.91	17.57
	Power Input	3.45	3.58	3.7	3.84	3.97	4	4.12	4.17	4.18	4.22	4.23	4.32
	COP	1.88	2.11	2.37	2.66	2.99	3	3.36	3.54	3.78	3.86	4	4.07
50	Capacity		7.16	8.33	9.69	11.27	11.41	13.11	14.03	15.01	15.46	16.06	16.7
	Power Input		3.98	4.12	4.27	4.42	4.47	4.58	4.65	4.65	4.7	4.7	4.81
	COP		1.8	2.02	2.27	2.55	2.55	2.86	3.02	3.23	3.29	3.42	3.47
55	Capacity			7.92	9.21	10.71	10.83	12.45	13.32	14.25	14.68	15.25	15.85
	Power Input			4.63	4.8	4.96	4.99	5.12	5.2	5.22	5.28	5.28	5.41
	COP			1.71	1.92	2.16	2.17	2.43	2.56	2.73	2.78	2.89	2.93

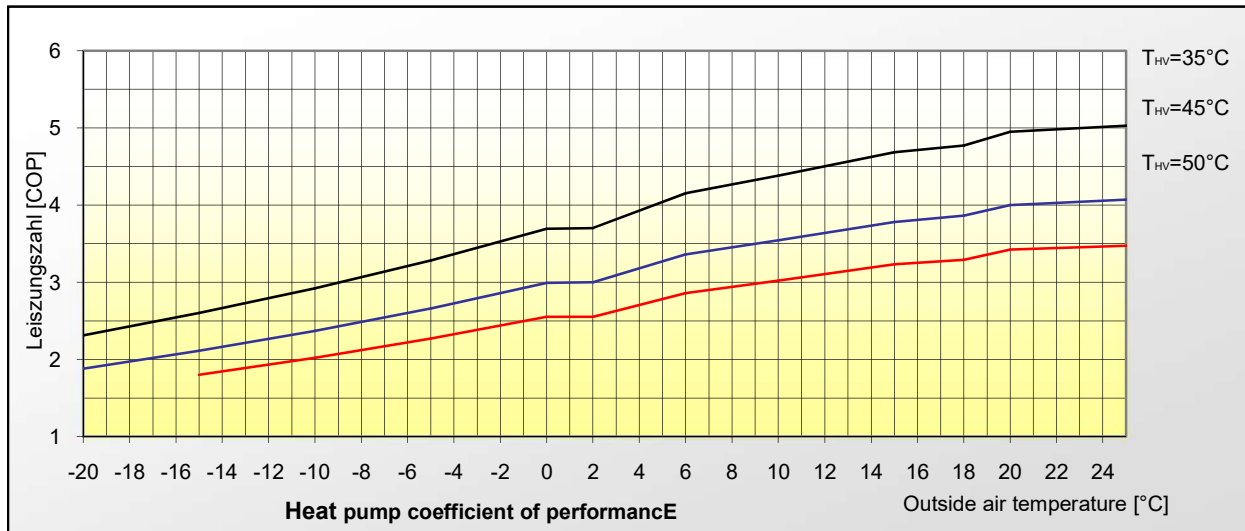
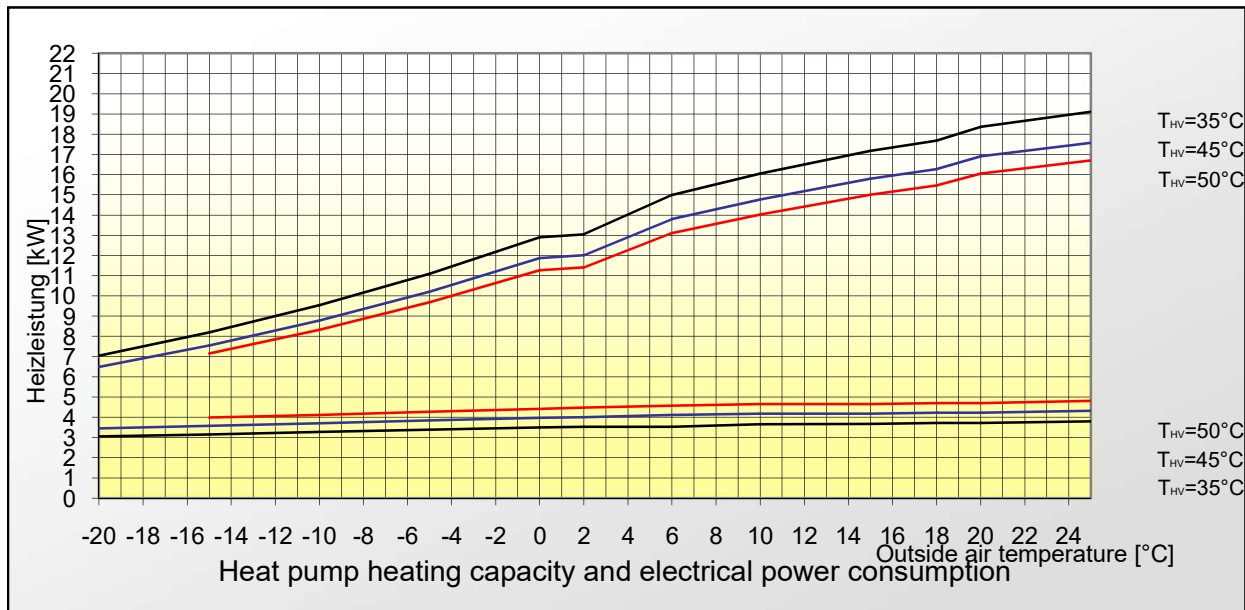

Installation

1. Installation method

Method 1

Only DHW

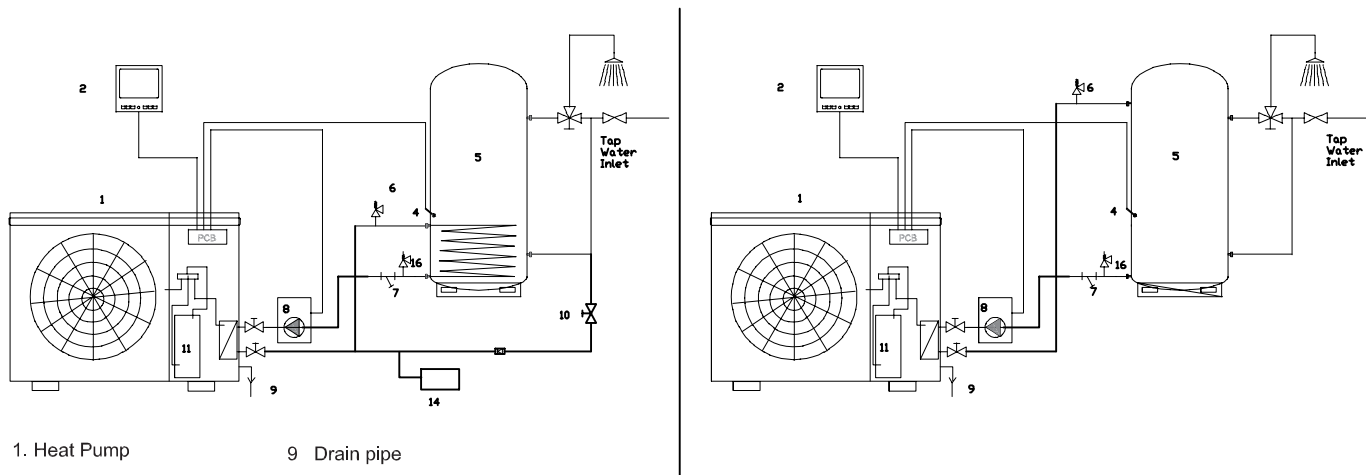

- 1. Heat Pump
- 2. Wired Controller
- 3. DHW water pump
- 4. DHW temp sensor
- 5. DHW water tank
- 6. Safety valve
- 7. Filter
- 8. Water pump
- 9. Drain pipe
- 10. Ball valve
- 11. Compressor
- 12. Air Conditioning plate heat exchanger
- 13. Hot Water Plate heat exchanger
- 14. Expansion Tank
- 15. Ball valve
- 16/17. Air discharge valve

Method 2

DHW with Room Heating

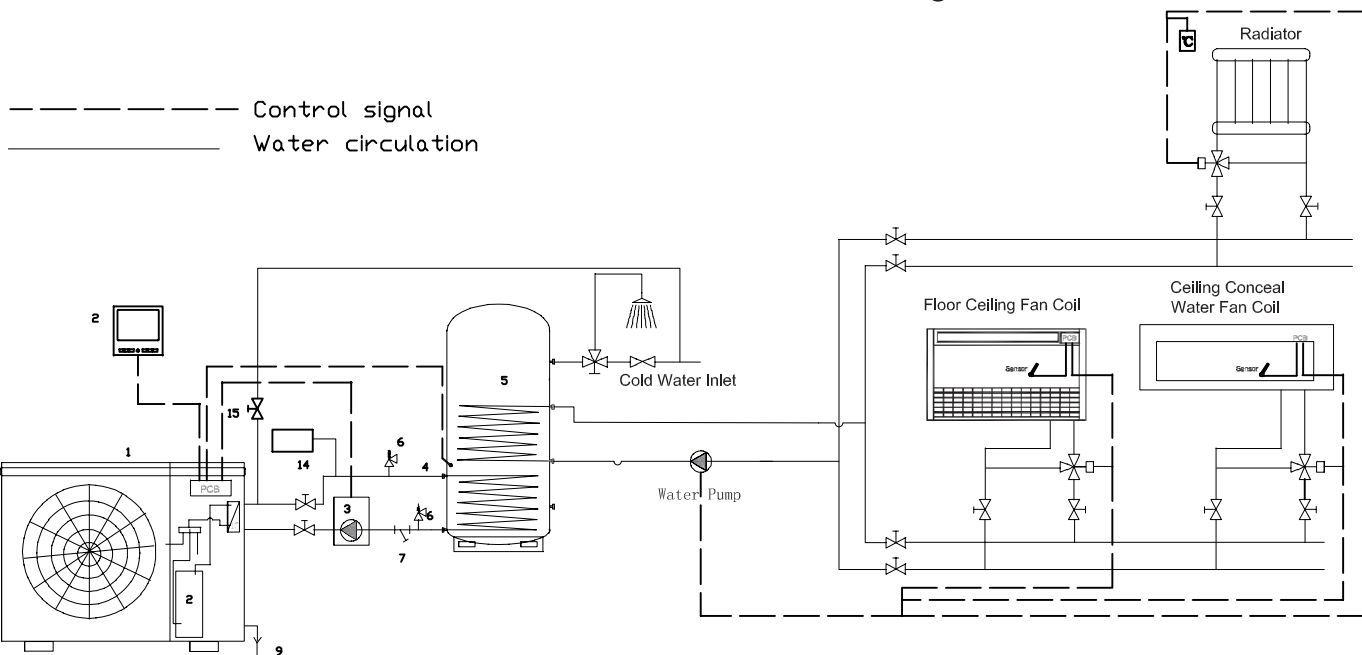

Method 3

Air Conditioning Heating and Cooling

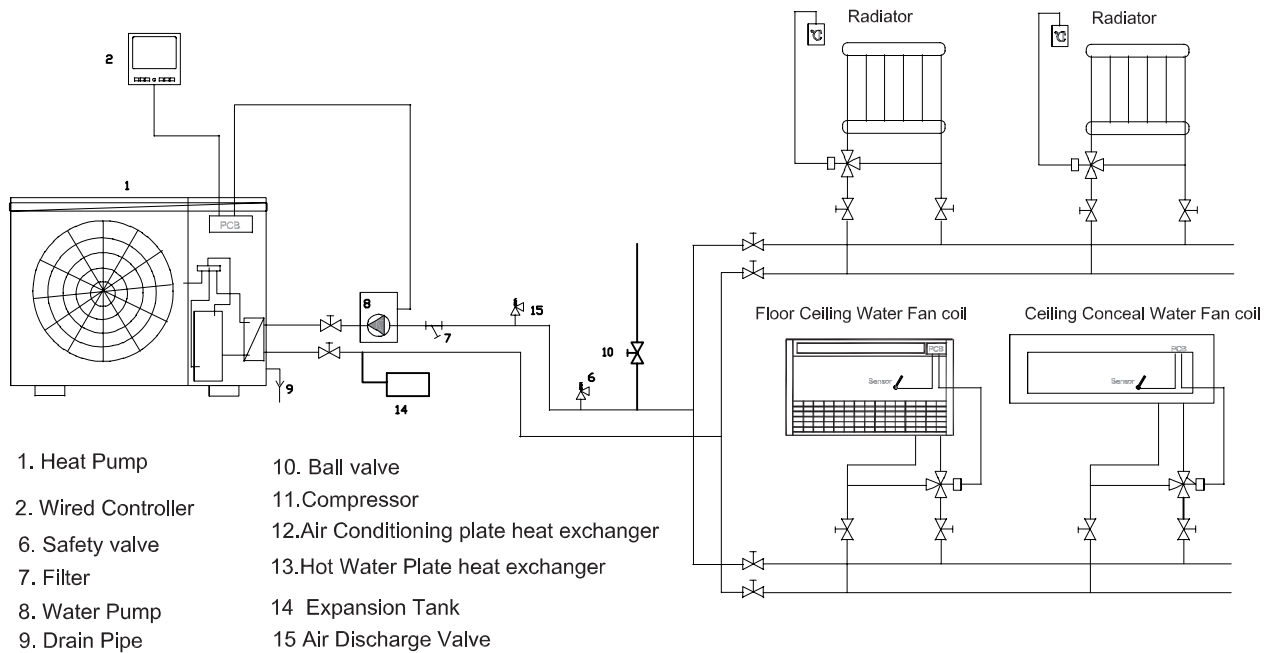

Method 4

Heating & Cooling & DHW

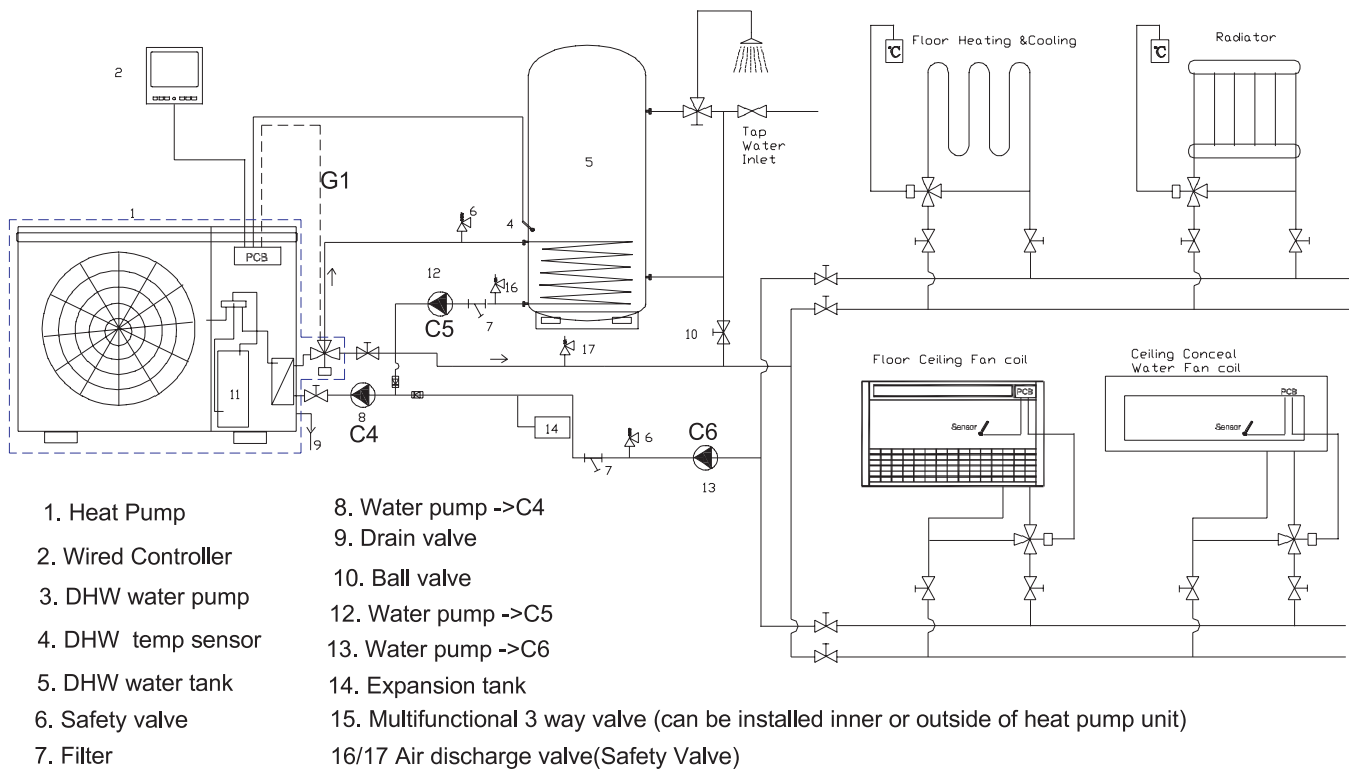

Note:

1. C4 water pump and multifunctional box can be built inside of heat pump according to order requirement.
2. C4 water pump can be used for both DHW and air conditioning water circulation.
3. installer should check the actual water resistance and make sure to keep enough minimum water flow volume, if necessary, more water pumps should be added for DHW (C5 water pump) and air conditioning (C6 water pump) water circulation. The water pump connection can be found in wiring diagram.
4. Safety valve (air discharge valve) should be installed at the top of the circulation system for easy air discharge. Air conditioning circulation can utilize the fan coil or radiator air discharge valve.

Installation

2. Installation with solar assistant

Application 1 Only DHW with Solar

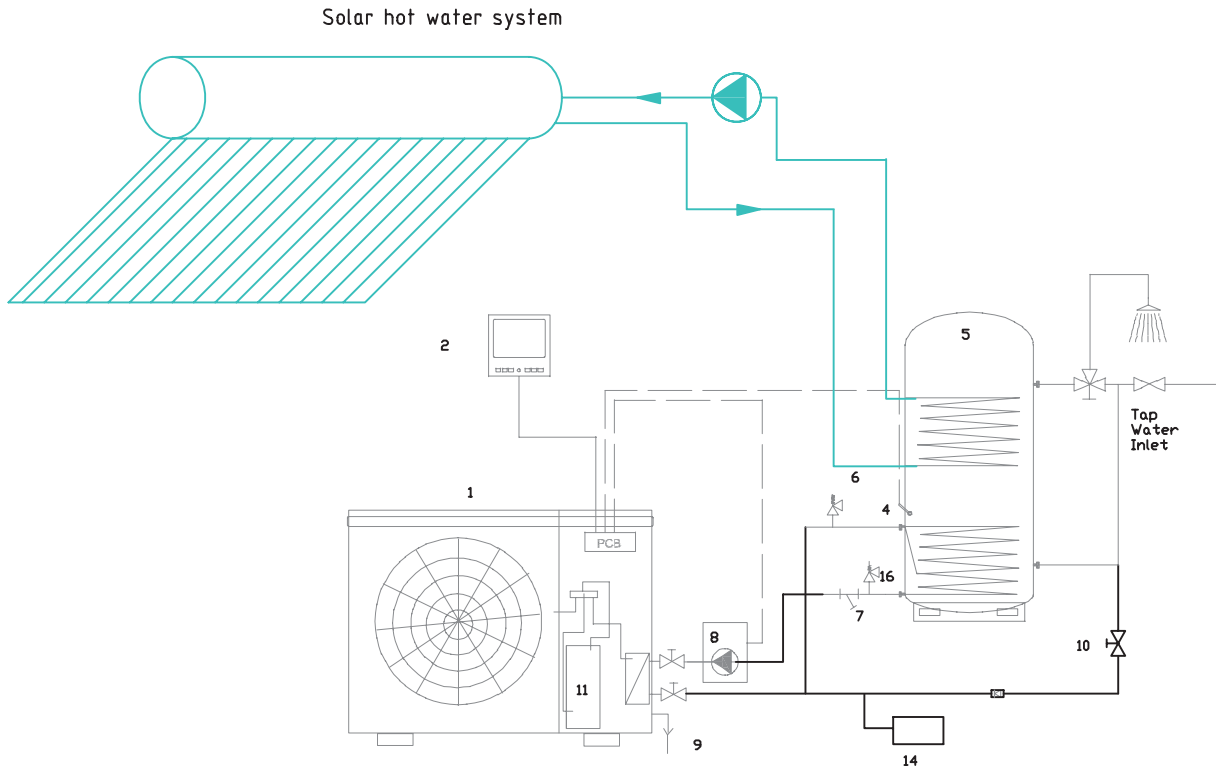

Application 2 Multifunctional heat pump with solar assistant DHW

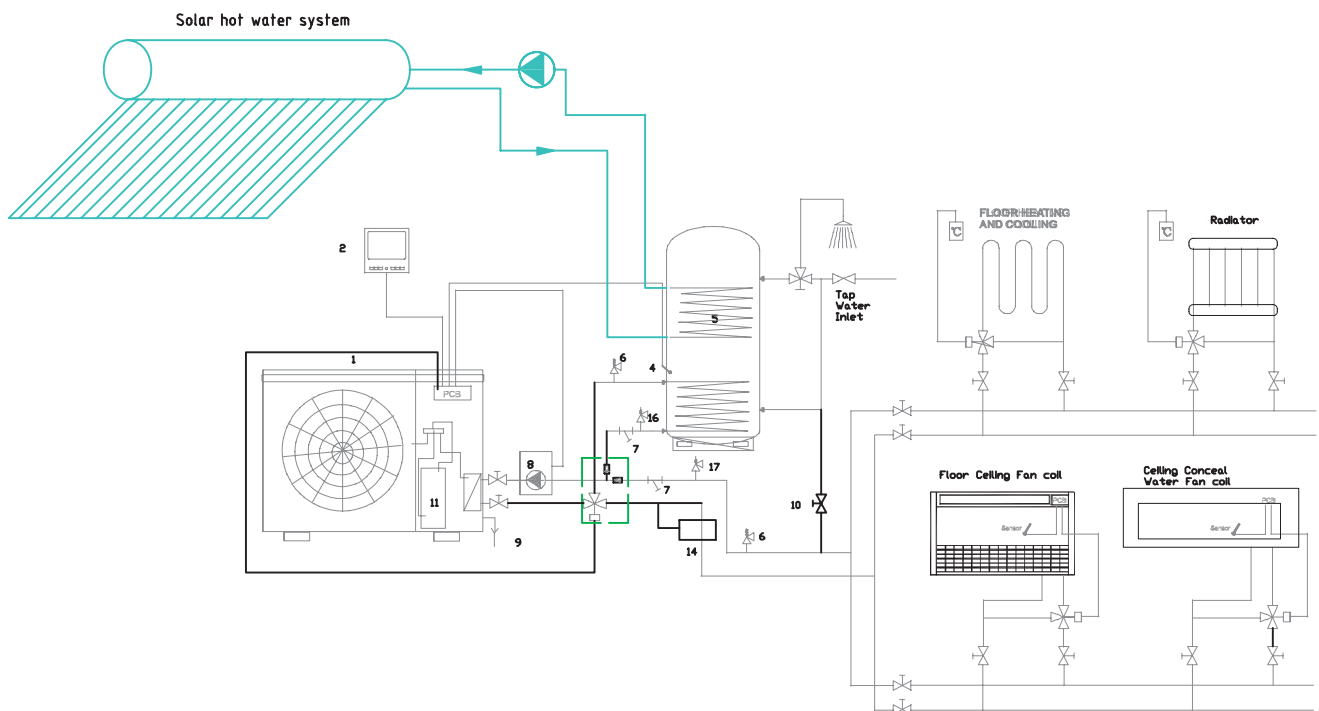

Installation

Application 3 The most energy saving application

Multifunctional heat pump application for solar assist for heating and DHW

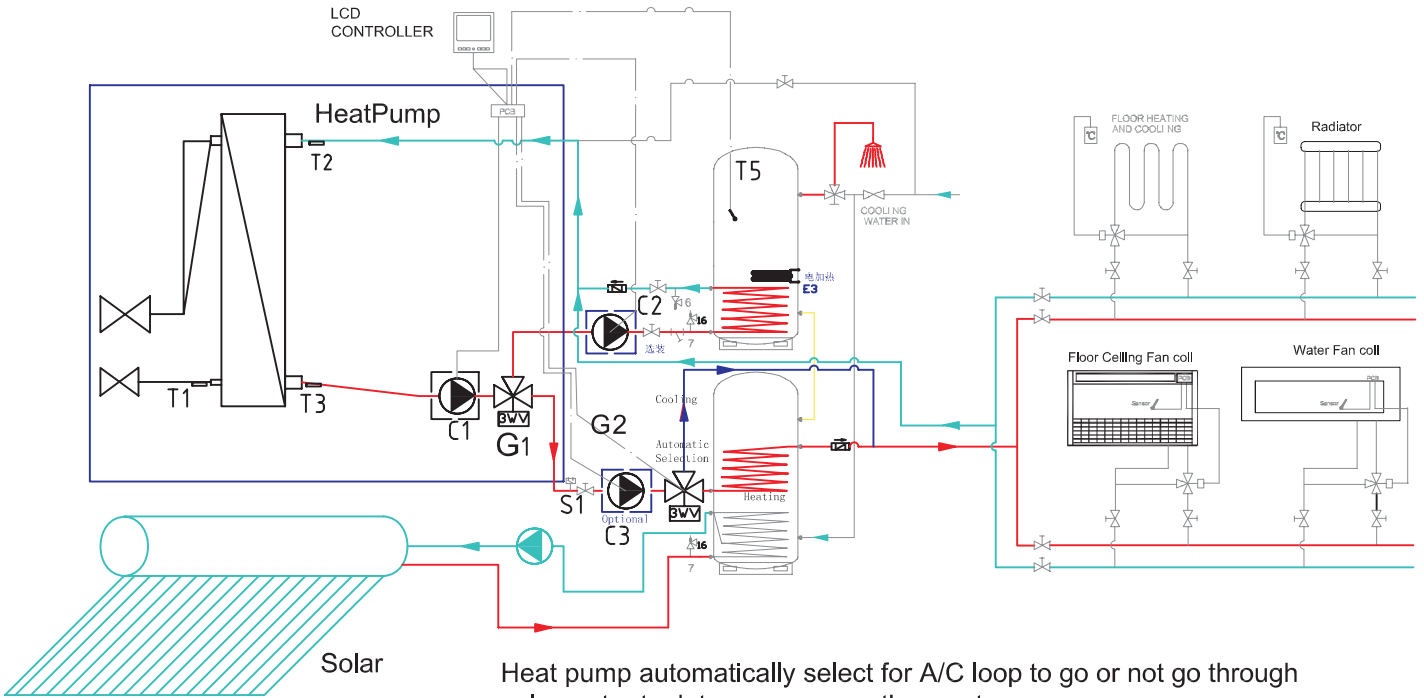

Heat pump automatically select for A/C loop to go or not go through solar water tank to save energy the most.

- G1: DHW and AC switching valve
- G2: Solar automatic selection valve

Installation position

Note!

Installation must be carried out by professional personnel.

- 1 If the unit is to be installed on the floor, its undercarriage should be heightened, to avoid ingress of accumulated water in rainy season. In snowy areas, it is important to prevent accumulated snow from blocking up the air-out. The recommended height is 20cm to 30cm.
- 2 Drain ditch or other facilities should be arranged under the outdoor unit, to avoid the environment influence because of water discharge.
- 3 To install the unit at balcony or top of building, the installation site must meet the allowable bearing capacity of building structure, without affecting the structural safety.
- 4 Ensure the unit is well ventilated, direction of air exhaust is kept away from windows of neighboring buildings, and the exhaust air cannot flow back. moreover, adequate service clearance should be kept around the unit.
- 5 The unit should not be installed at places accompanied with oil, inflammable gases, corrosive components e.g. sulfur compound, or high-frequency equipment.
- 6 The unit must be installed upon reliable machine base or framework. Weight capacity of framework should be 3 times of the body weight, and safeguard measures should be taken to avoid malfunction of fastenings.
- 7 The unit should not be installed at sites with typhoon/ earthquake hazards. Midair installation should be avoided as much as possible, for machine falling may result in severe accident.

Installation in exceptional circumstances(unit:mm)

No obstacle in front of the unit

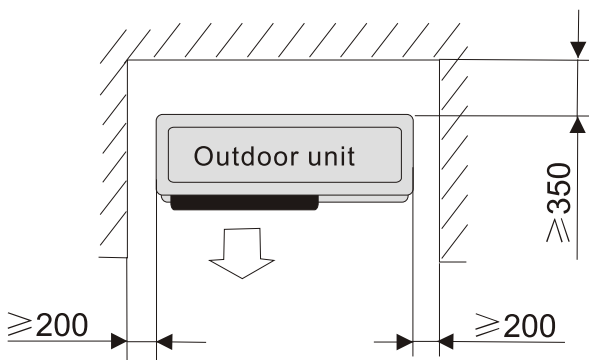

Obstacle above the unit

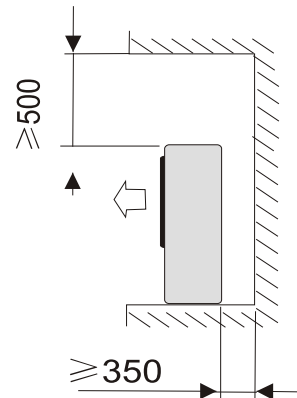

Obstacle in front of the unit

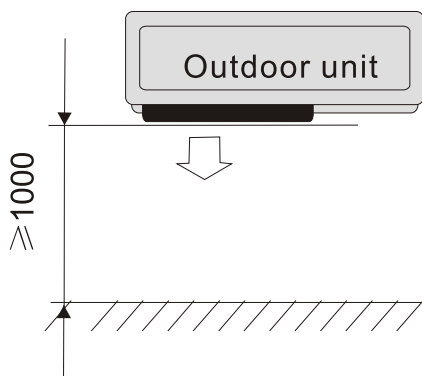

Several units in a row

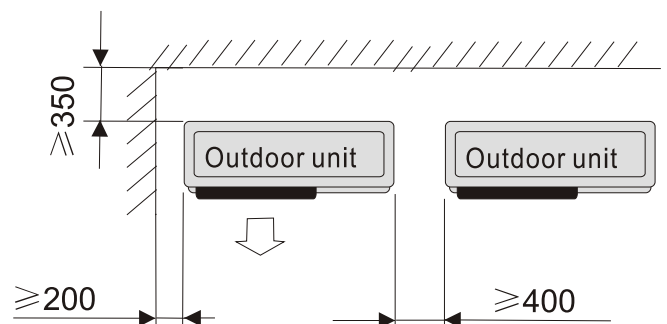

Electric connection

General

Note!

Electrical installation and service must be carried out under the supervision of a qualified electrician. Electrical installation and wiring must be carried out in accordance with the stipulations in force.

The heat pump must not be connected without the permission of the electricity supplier and must be connected under the supervision of a qualified electrician.

Wires, spare parts and materials etc. must satisfy the relevant standards issued by the host country or region.

The heat pump does not include an isolator switch on the incoming electrical supply. The power supply cable must be connected to a circuit-breaker with at least a 3 mm breaking gap. Incoming supply must comply with the technical requirements, with ground wire, via a distribution board with fuses.

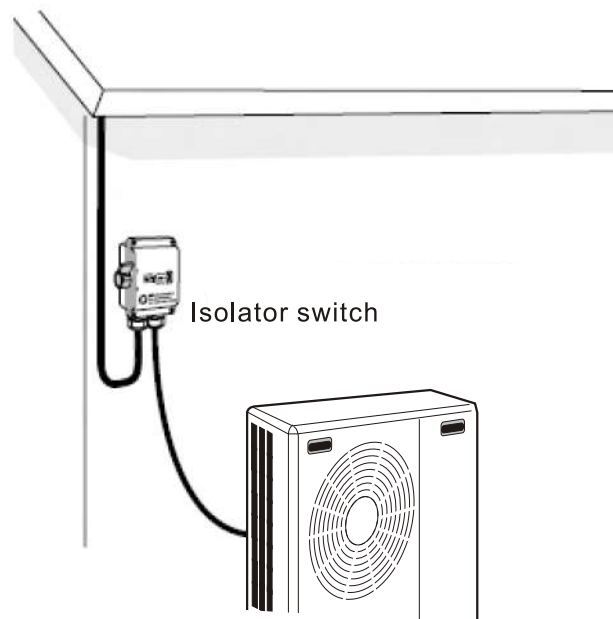

If an insulation test is to be carried out in the building, please make sure to disconnect the heat pump.

To avoid the possibility of false action caused by electromagnetic coupling, the communication wire must be STP(Shielded Twisted Pair). The size of communication wire should not less than 0.5mm^2 .

Electric connection

Wiring Diagram (with built-inside water circulation pump)

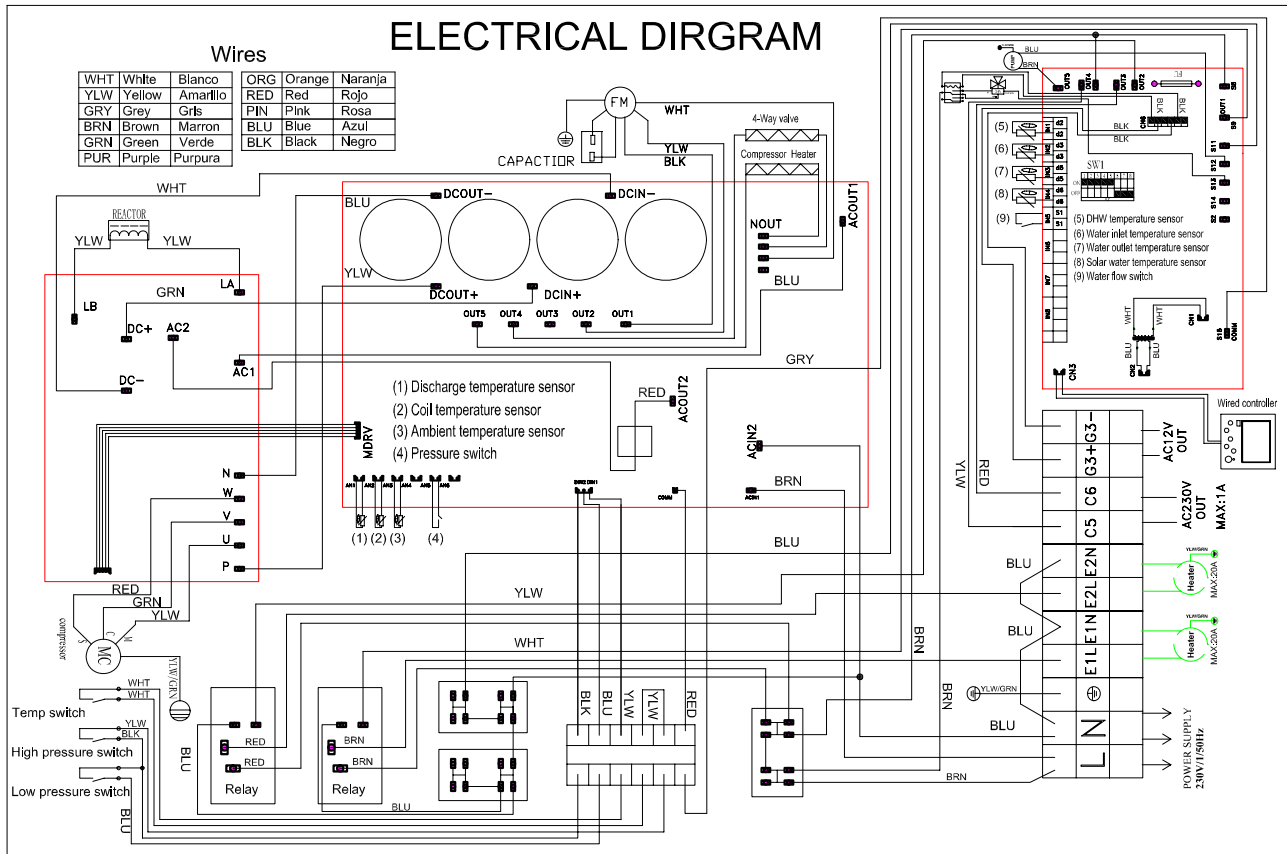

Wiring Diagram (No built-inside water circulation pump)

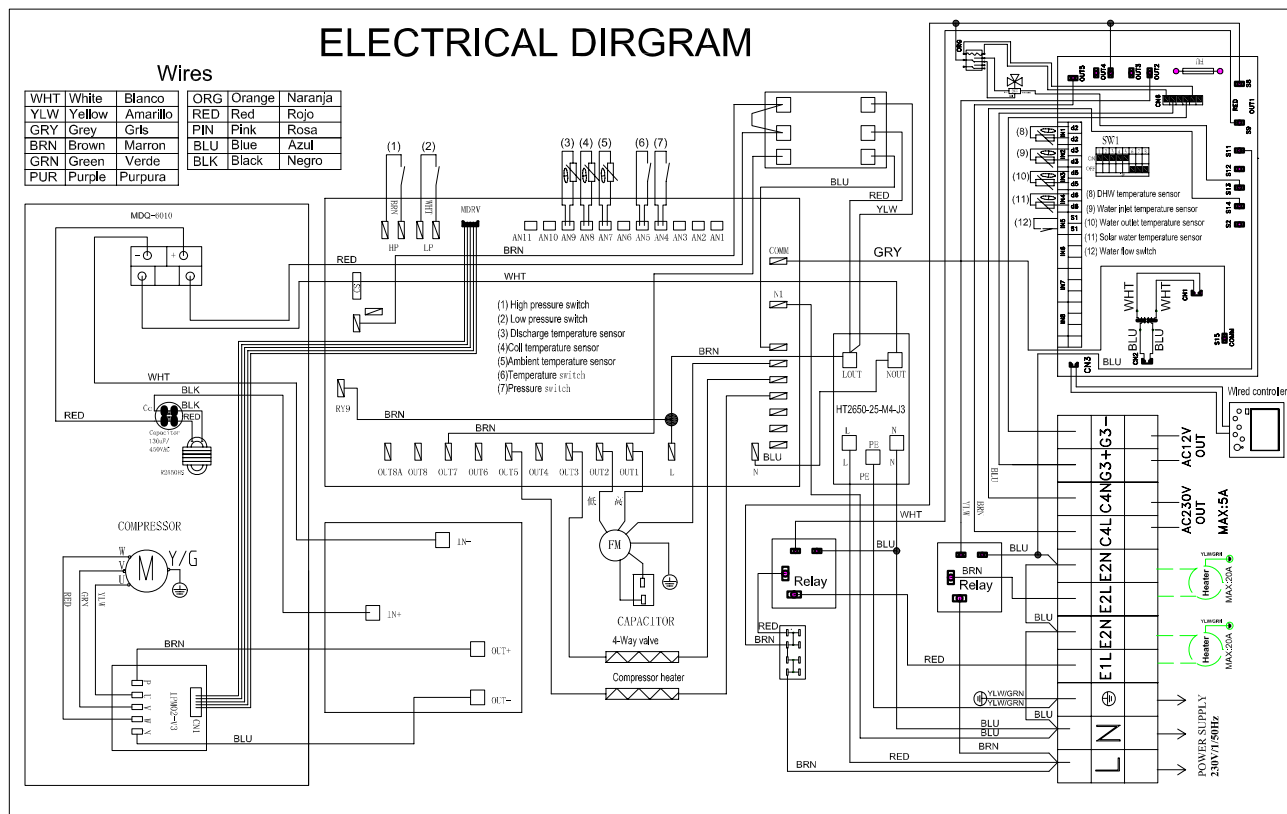

Test run

Preparation

After finish the installation tasks, please check the items:

- 1 Check the dip switch setting and short wiring
- 2 Power cable

Check if the power cable is connected correctly, and check if the screws have been screwed down.

Please use specified cables.

- 3 Communication wire

Check if the communication wire is connected correctly.

Please adopt specified communication wire.

- 4 Water circuit

Check if the water pipes are correctly connected, and the pipe dimensions are correct.

Heatproof measures must be taken for water outlet pipes and water inlet.

Check if all the shut off valve and manual valve is opened, check if all the joint is fastened.

Water or Brine Filling

1 with water pipe connected to the unit's water system, and open all the air exhaust valves in water system and fill water into the system. Keep the air exhaust valve open until there is continuous water coming out of the air exhaust valve. Then close the air exhaust valve.

2. Discharge the air for both domestic hot water system and air conditioning water system, including all usage terminals such as domestic hot water tank, fan coils, radiators and etc. To make sure all system are full of water and there is no air inside the water system.

Note!

To avoid the heat pump to be frozen, if the air temp is possible to be under zero degree in winter, you need to use brine(glycol) to replace pure water in case of electricity cut off accident during winter

Running

Turn on the heat pump

select heating, domestic hot water mode, check whether the unit is running properly or not, the compressor will be started in 3~5 minute after powered on.

MOST IMPORTANT !

1. Always keep electricity connection with heat pump to enable the antifreeze function.
2. Select a big enough water pump for the air conditioning water circuit.
3. Make sure it is not in cooling mode during first operation or test running until you make sure the air conditioning circulation pump is working properly and water is recycling smoothly.