



Fan Coil Unit

Operation and Installation Manual



Large Air Flow High Static Pressure Fan Coil

- 2 Pipe System

FC06, 08, 10, 13, 15, 16, 19, 20, 25, 32, 38

*Please read this manual before using the fan coil.

*Please keep this manual for future use

Table of Contents

1. Safety and User Information.....	02
2. Product Introduction.....	05
3. Dimensions, Weight and Wiring diagram.....	12
4. Installation... ..	14
5. Commissioning.....	22
6. Maintenance and Troubleshooting... ..	24

Note:

All illustrations and contents in this manual are provided for information only. We will continuously improve the products in aspects of product dimensions, performances, materials and structures without prior notification.

1. Safety and User Information

Safety instructions

The Large Air Flow & High Static Pressure fan coil units are developed and manufactured in accordance with the state-of-the-art technological standards and established technical safety norms and regulations. The Large Air Flow & High Static Pressure fan coil units comply with the Machinery Safety Directive.

The Large Air Flow & High Static Pressure fan coil units are reliable and satisfy high quality standards. This product range combines advanced technology with a high level of user friendliness and ease of maintenance.

However, all fan coil units inevitably pose residual risks of injury to the user or third parties or material damage to the unit or other objects. For this reason, you should take into account and follow all safety instructions. Ignoring these safety instructions is connected with risks to your health and safety, can lead to the environmental damage and/or extensive material damage.

Observing the safety instructions in the operation manual will help you to avoid risks, ensure economical operation of the unit and enjoy full benefits of the product.

The safety aspects covered by this Chapter are valid for the entire operation manual. To ensure our own safety consider the following safety instructions.

**THE SAFETY INSTRUCTIONS AFTER LABEL
'  ' IS CONSIDERED AS WARNING WHICH
MEANS INCORRECT OPERATION MAY RESULT
IN SEVERE CONSEQUENCES OF DEATH OR
SERIOUS INJURIES!**

ELECTRICAL HAZARD!

Before carrying out any work on the unit, power the unit down to avoid injury from electrical current. Check that the unit is isolated and ensure that the appropriate point of the unit for the on-site power supply is secured against being switched back on.

DANGER OF SCALDING!

Before performing work on the valves or the inlet or outlet pipes, seal off the heating or cooling medium inlet to prevent scalding. Do not commence work before the heating medium has cooled down.

DANGER OF ROTATING UNIT PARTS!

Rotating fan wheels can cause injury! Before performing any work on the unit, ensure that it is powered down. Ensure that the appropriate point of the unit for the on-site power supply is secured against being switched back on.



DANGER OF OVERHEAD LOADS!

Wear a helmet and safety boots to prevent injury from falling components, especially when fitting the unit to the ceiling. Ceiling installations should always be performed by two people.



PERSONAL INJURY!

Always wear protective gloves when moving or fitting the unit to avoid injury from sharp edges.

Important notes

The fan coil units are end units of chilled/hot water air conditioning system featuring high profession and high technological requirement, therefore, the unit shall be installed, operated and maintained only by qualified, specially trained and authorized staff.

Proper use

Large Air Flow & High Static Pressure fan coil units are exclusively designed for ventilating, heating, filtering and cooling purposes. Chilled water/Hot water may be used as the medium.

The following limit values apply to the medium for operating Cu/Al heat exchangers:

		Unit	Value
pH value (at 20 °C)			7,5 – 9
Conductivity (at 20 °C)		µS/cm	< 700
Oxygen content	O ₂	mg/l	< 0,1
Total hardness		°dH	1 – 15
Dissolved sulphur	S		not detectable
Sodium	Na ⁺	mg/l	< 100
Iron	Fe ²⁺ , Fe ³⁺	mg/l	< 0,1
Manganese	Mn ²⁺	mg/l	< 0,05
Ammonium content	NH ₄ ⁺	mg/l	< 0,1
Chloride	Cl ⁻	mg/l	< 100
Sulphate	SO ₄ ²⁻	mg/l	< 50
Nitrite	NO ₂ ⁻	mg/l	< 50
Nitrate	NO ₃ ⁻	mg/l	< 50



DAMAGE TO THE UNIT!

On open systems (e.g. when using well water observe the limit values stated in above table), the used water should additionally be cleansed of suspended matter using a filter which should be located at the inlet. Otherwise there is a risk of erosion by suspended matter.

You also have to ensure that the unit is protected from dust and other substances that can cause acidic or alkaline reaction when combined with water (aluminum corrosion).

- The Large Air Flow & High Static Pressure fan coil units may only be used indoors.
- The Large Air Flow & High Static Pressure fan coil units is suitable for ceiling installation. The unit is considered to be used in an improper manner if it is applied for other purposes or a purpose that is not covered by the scope of the given operation manual. The manufacturer or supplier is not liable for any resulting damage: the user alone bears the full risk.

The user is responsible for proper use. Proper use also stipulates the observance of the operation manual and the inspection and maintenance conditions defined by the manufactures.

Improper use

The Large Air Flow & High Static Pressure fan coil may not be operated:

- In locations where there is a risk of explosion
- In wet areas or
- In locations with high dust levels or aggressive air.



PERSONAL INJURY & MATERIAL DAMAGE!

Improper use can cause personal injury and material damage.

2. Product Introduction

Features and benefits

The fan coil units have become a hall mark for de-central air treatment, with top levels of comfort and truly impressive cost-effectiveness. A selection of our versatile fan coil units assures that we offer you the perfectly matching product solution for each of your individual requirements.

Practical Orientation

The fan coil units offer an extensive portfolio of solutions for all applications involving de-central air handling.

Effectiveness

The Large Air Flow & High Static Pressure fan coil units guarantee cosy and comfortable room atmosphere.

Space savings

The Large Air Flow & High Static Pressure fan coil units' compact design assures optimal use of available space by their design and installation possibilities.

Flexible

Depending on the model type, the customer enjoys a selection among possibilities of media connection to the heat exchangers- as well as the possibility of implementing heating and cooling.

Quietness

Sophisticated systems mean that the Large Air Flow & High Static Pressure fan coil units are characterize by a minimum of noise emission.

Functionality

The Large Air Flow & High Static Pressure fan coil units offer highly functional controller concepts and optimal interfacing with building management systems

Stylishness

The modern appealing design of the Large Air Flow & High Static Pressure fan coil units is truly impressive.

Cost effectiveness

The Large Air Flow & High Static Pressure fan coil units have become the effective standard solution in many and various industrial segments for comfortable economical air conditioning.

Profitability

The Large Air Flow & High Static Pressure fan coil units operate with low maintenance and follow-up costs.

Nomenclature

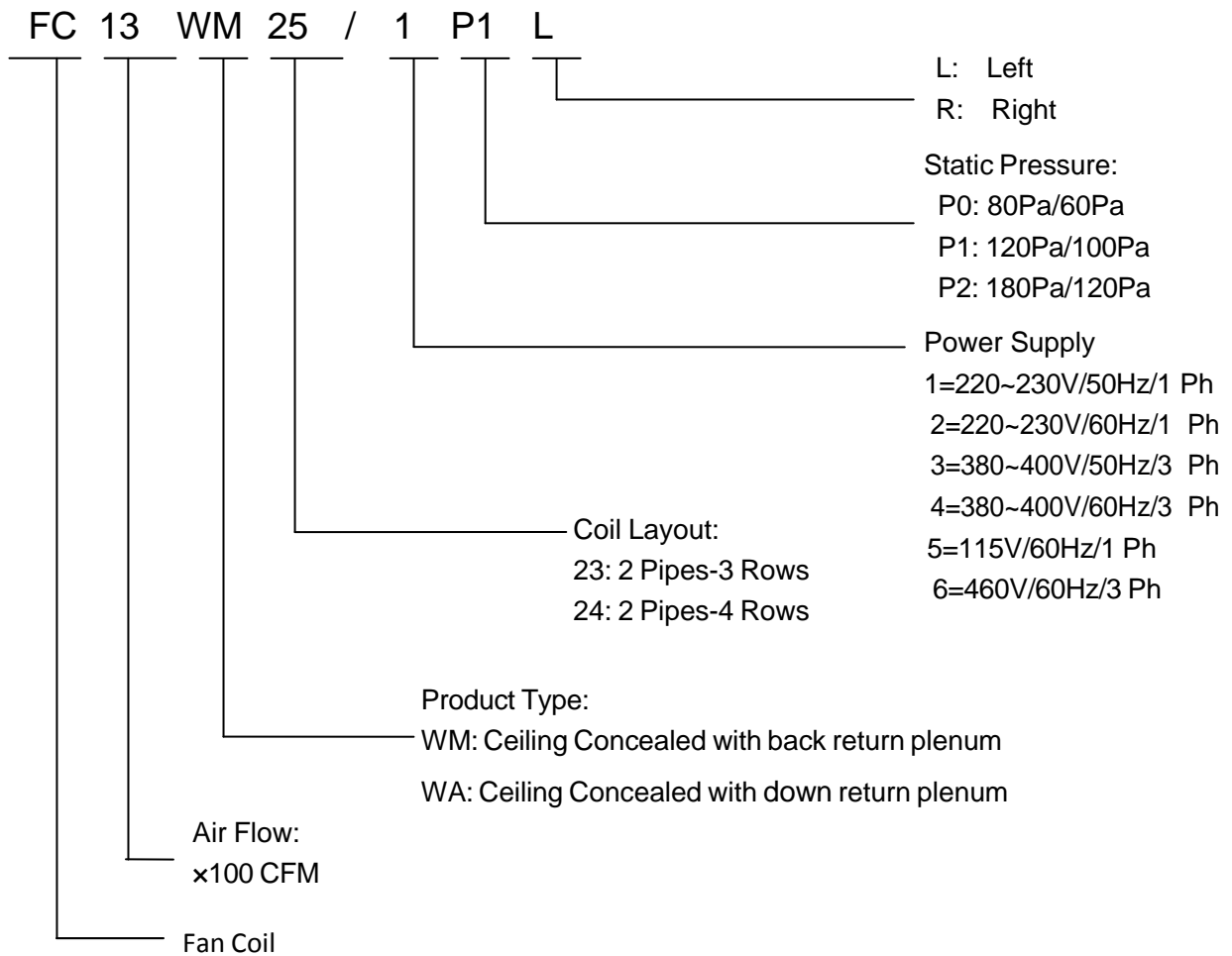

The Large Air Flow & High Static Pressure Fan Coil can be divided by coil layout as:

- 2 pipe system 3 rows
- 2 pipe system 4 rows

The Large Air Flow & High Static Pressure Fan Coil can be divided by product type as:

- WA: Ceiling Concealed - with down return plenum
- WM: Ceiling Concealed - with back return plenum

Operating limits

Unit and heat exchanger	Values
Max. operating pressure/temperature	1,6 MPa (16 bar) / 85 °C
Max. permissible ambient temperature	40 °C
Min. permissible ambient temperature	2 °C
Operating voltage	220~230V AC (50Hz or 60Hz) *[Refer to nameplate]
Power consumption/protection class	*[Refer to nameplate]

! DAMAGE TO THE UNIT!

Please refer to unit nameplate to know the right power supply! Wrong power supply may damage the motor and unit permanently!

Unit Components

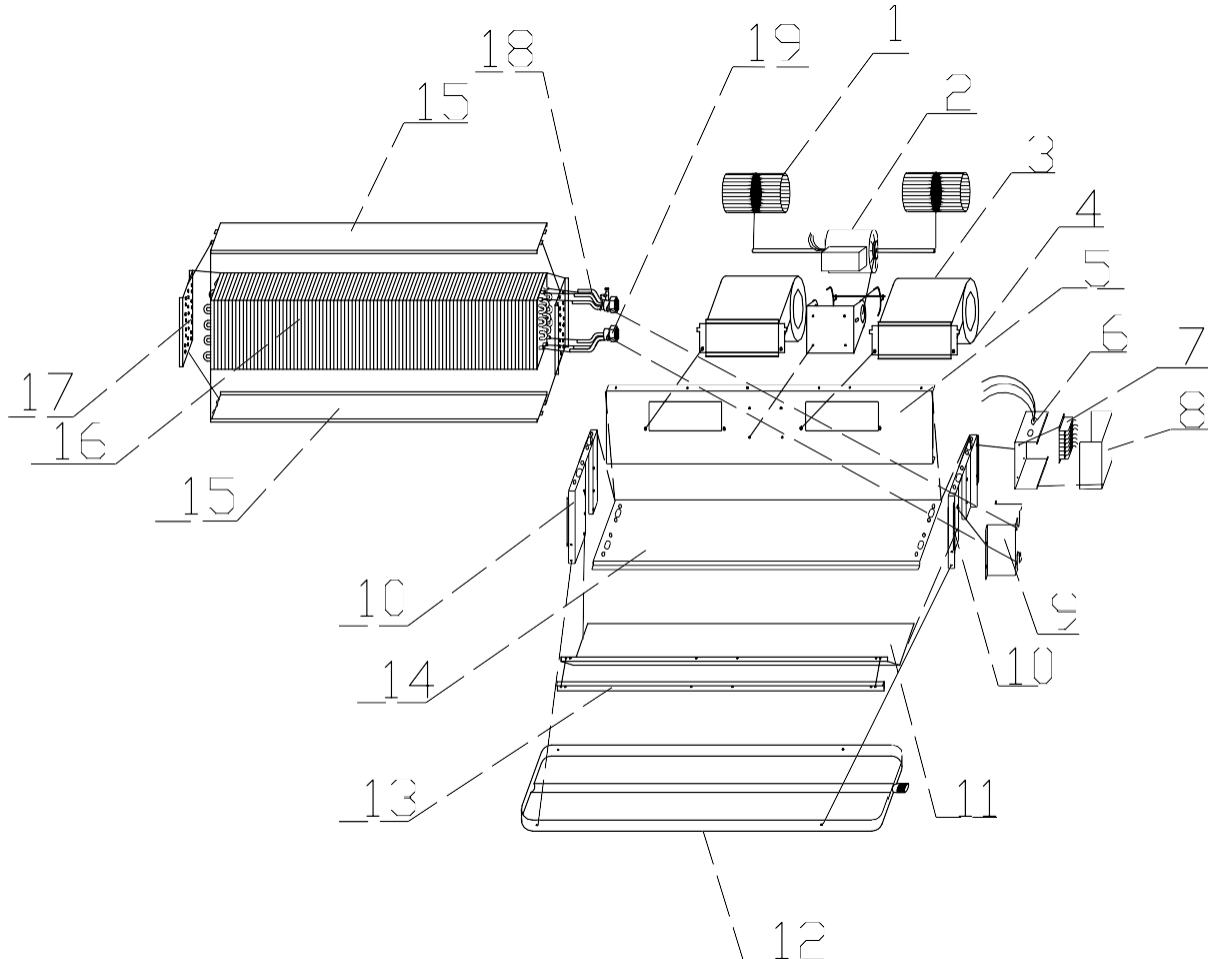

- | | |
|--------------------------------|--------------------------------------|
| 1. Fan blower | 10. Unit casing (lateral left) |
| 2. Fan motor | 11. Unit casing (bottom) |
| 3. Fan shell (up) | 12. Drain pan |
| 4. Fan shell (down) | 13. Fixing frame |
| 5. Fan supporting board | 14. Unit casing (top) |
| 6. Bottom cover electrical box | 15. Coil frame casing (top & bottom) |
| 7. Terminal block | 16. Coil |
| 8. Front cover electrical box | 17. Coil frame casing (lateral) |
| 9. Connector fixing board | 18. Water inlet/outlet connector |

Note:

Above exploded view is used for illustrative of unit construction only, it may be different from the unit you received, please refer to the unit itself.

Specifications

Please refer to specification sheet in next pages.

Specification	Model	FC06	FC08	FC10	FC13	FC15	FC16	FC19	FC20	FC25	FC32	FC38	
Air Flow	H	CFM	629	841	1053	1282	1511	1600	1911	2000	2558	3205	3847
		m ³ /h	1070	1430	1790	2180	2570	2720	3250	3400	4350	5450	6540
	M	CFM	541	732	895	1085	1374	1392	1648	1740	2173	2685	3167
		m ³ /h	920	1244	1522	1845	2336	2367	2801	2958	3694	4565	5384
	L	CFM	472	622	790	959	1185	1201	1421	1501	1920	2338	2688
		m ³ /h	803	1058	1343	1630	2014	2041	2415	2550	3264	3974	4570
Total Cooling Capacity kW	H	6.10	7.50	9.00	10.80	12.65	13.68	14.66	16.68	19.21	25.70	29.32	
	M	5.49	6.68	8.19	10.28	11.88	11.22	13.75	13.68	18.30	24.03	27.32	
	L	5.06	6.30	7.65	9.43	11.21	10.26	13.11	12.51	17.47	22.68	26.38	
Sensible Cooling Capacity kW	H	4.60	5.60	6.50	8.20	9.40	10.40	11.80	12.68	14.70	19.60	23.10	
	M	4.00	4.82	5.66	7.22	8.40	8.73	9.91	10.65	13.01	16.66	19.17	
	L	3.50	4.31	5.07	6.31	7.60	7.90	9.09	9.63	11.63	15.09	17.79	
Heating Capacity kW	H	9.30	11.50	14.10	16.20	18.97	21.60	21.99	25.02	28.82	38.61	43.98	
	M	8.09	10.12	12.55	15.75	17.81	17.71	20.25	20.52	27.21	36.40	40.30	
	L	7.72	9.66	11.84	15.20	16.35	16.20	18.50	18.77	26.29	34.60	38.84	
Power Input W	80Pa-H	180	240	340	390	656	512	710	640	800	1480	1570	
	120Pa-H	240	370	450	506	835	600	880	750	946	1892	1760	
	180Pa-H	320	500	600	680	890	800	950	1000	1240	2070	1920	
Max Current	A	1.5	2.3	2.7	3.1	3.8	3.6	4.3	4.5	5.6	9.0	8.3	
Static Pressure	Pa	80	80	100	120	120	120	120	120	120	150	150	
Noise Level dB(A)	80Pa-H	48	49	50	52	55	56	56	57	60	61	62	
	120Pa-H	51	52	53	55	58	58	59	60	62	64	65	
	180Pa-H	53	55	56	58	60	61	62	63	65	67	67	
Water Flow	kg/h	1000	1200	1500	1857	2175	2	2521	3	3265	4420	5043	
	l/s	0.278	0.333	0.417	0.516	0.604	0.001	0.700	0.001	0.907	1.278	1.400	
Water Resistance	kPa	8.7	11.7	16.8	25.4	35	38	43.5	40	25.4	39.5	48.7	
Fan Type		Forward curve centrifugal fan											
Motor	Type	Three speed asynchronous fan motor											
	Insulation	Class B											
	Power Supply	220~230V/1Ph/50 or 60Hz											
Coil	Type	Seamless copper mechanically expanded into aluminum fins											
	Rows	3											
	Max. Working Pressure	1.6 MPa											
Inlet/Outlet Water Pipe		ZG3" /4			1" MPT				1 1/4" MPT				
Condensate Water Pipe		3/4" MPT											
Unit Dimension	mm(W/D/H)	980*610*365	1080*610*365	1180*610*365	1380*610*365	1480*610*365	1480*610*365	1280*660*465	1380*660*465	1780*660*465	1980*660*465	2180*660*465	
Packing Dimension	mm(W/D/H)	1010*640*370	1110*640*370	1210*640*370	1410*640*370	1510*640*370	1510*640*370	1310*690*470	1410*690*470	1810*690*470	2010*690*470	2210*690*470	
Unit Weight	kg	37	40	47	52	58	60	62	65	80	103	111	
Gross Weight	kg	42	46	54	60	67	67	70	73	88	112	120	

Note:

1. Nominal Testing condition:

Cooling: entering air temp 27°C DB/19.5°C WB; entering water temp 7°C, leaving water temp 12°C;

Heating: entering air temp 21°C; entering water temp 60°C, the same water flow as in cooling;

2. Sound pressure level are measured in acoustic room, position of the measure point is 1m in the front and 1m below the vertical center line of the unit;

3. Static pressure is measured without filter and air outlet.

3. Dimensions, Weight and Wiring diagram

Dimensions

Ceiling Concealed with down/back return plenum

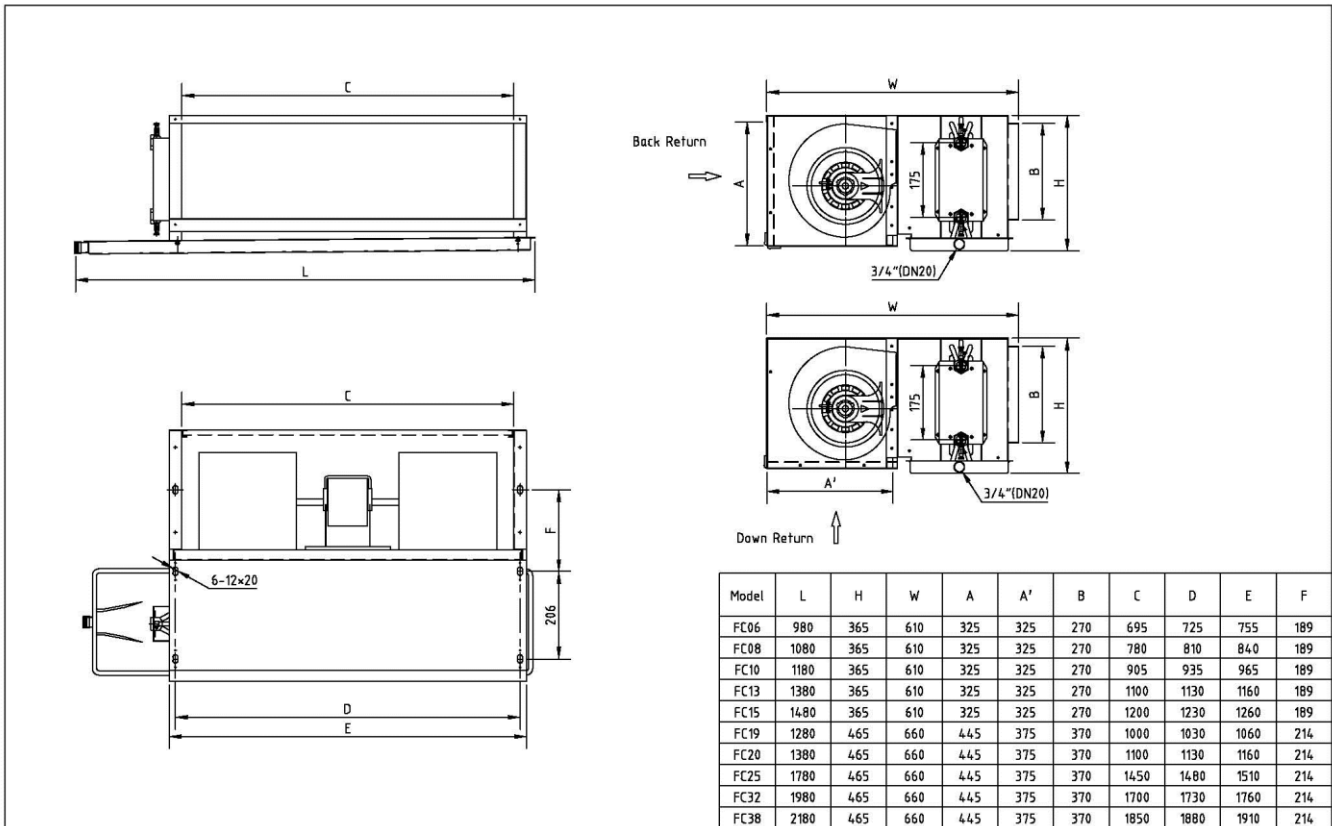

Weight/kg

Ceiling Concealed with down/back return plenum

Model	FC06	FC08	FC10	FC13	FC15	FC19	FC25	FC32	FC38
3 Row	54	54	57	65	68	71	91	103	111

Wiring diagram

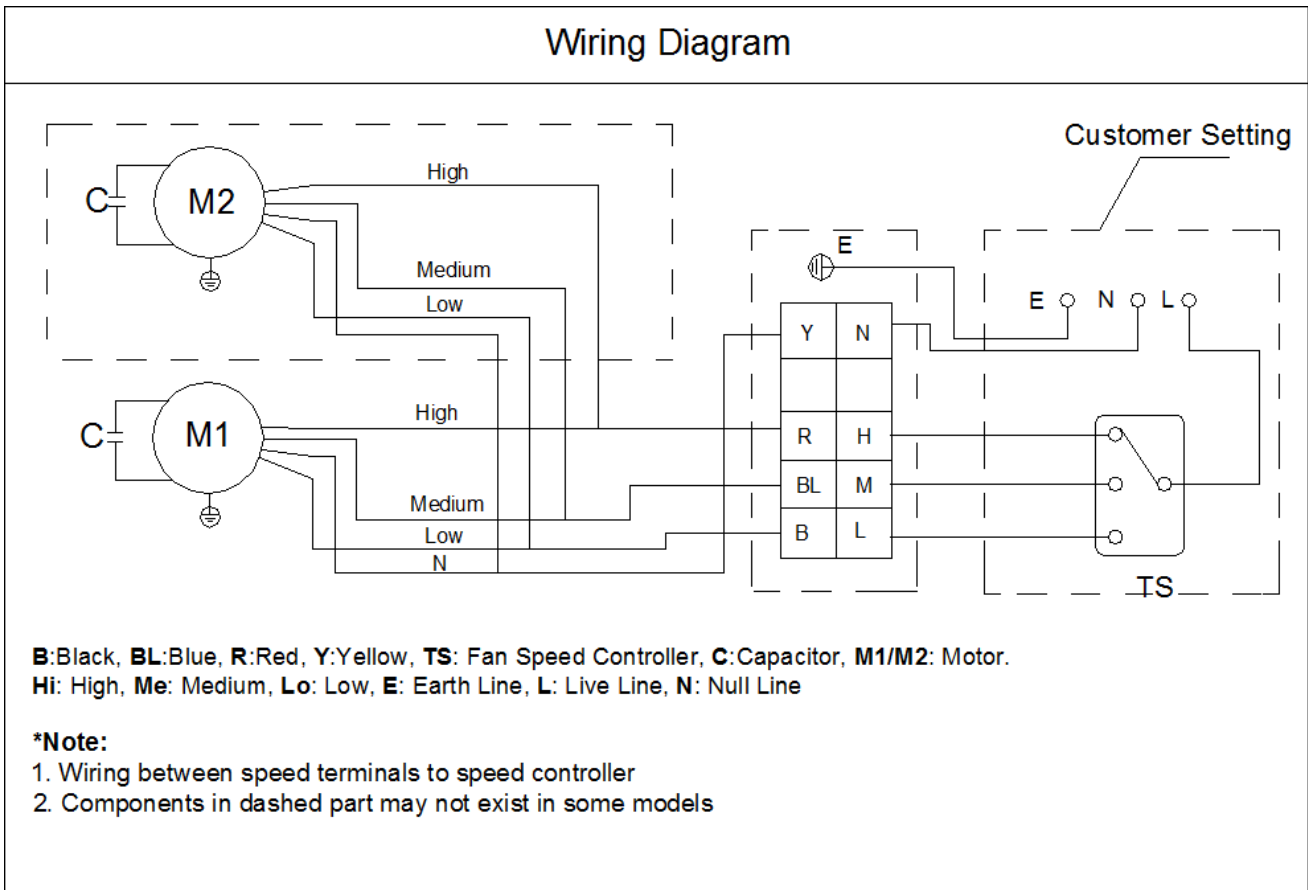

NOTE!

- Before carry out any wiring connection, always refer to the wiring diagram sticked on the back cover of the electric sheet box for the right information.
- In order to protect the thermostat or three speed switch, it is recommend to install relay/contacter as indicated in above wiring diagram.

2. Installation

Checking and acceptance

Each fan coil is packaged in corrugated cartons/wooden framed package to avoid damages during transportation, handling and site placement. To make sure no damages occurred due to transportation, please follow below steps to check upon receiving the equipment:

- a) Before acceptance, please check if each unit shows any abnormal facts, if carton edges and corners are in good conditions and if there are obvious carton damages;
- b) For any obvious carton damages, please immediately unpack to inspect the unit itself. If the unit is indeed damaged, please indicate on the receipt and refuse to accept. Please also check accessories;
- c) Check hidden damages of the unit;
- d) If any hidden damage is found, do not move the unit on the site. The receiver has the obligation to evidence such damage does not occur after delivery. Meanwhile, please stop unloading and take photos for reference;
- e) If damages are found, please notify the carrier, and request the carrier and the receiver to conduct a joint inspection;
- f) Do not repair it yourself before inspection and confirmation by the carrier representative has been made;
- g) After confirmation of damages, please contact related persons for replacement.

Transport

DAMAGE TO UNIT AND PERSONAL INJURY!

- Use protective gloves to avoid injury due to sharp edges.
- Ensure that at least two people carry the fan coil to avoid injury.
- In case of deliveries on pallets, use only lifting and transport vehicles with sufficient carrying capacity.
- Secure the load during transit to prevent it from tipping or falling.

4.2.1 Transport unit

The fan coils should only be transported and lifted from both sides at the top of the basic unit body, or to be lifted by forklift. Refer to below indication.

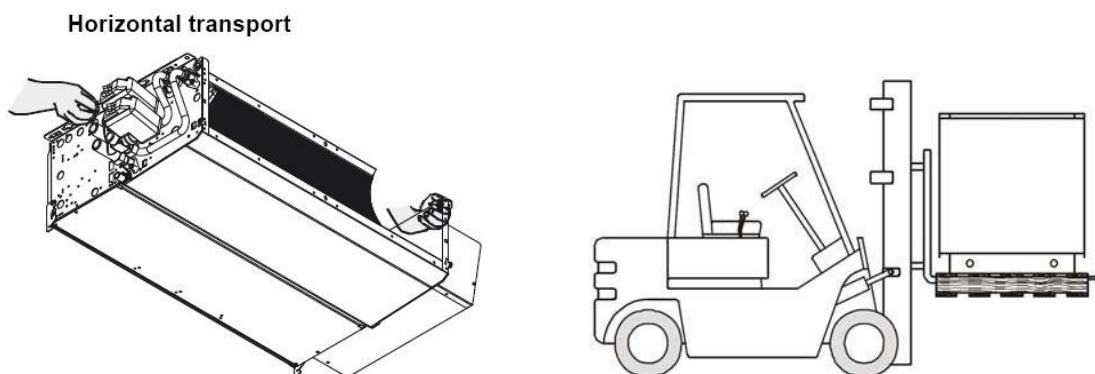

In case of lifting/transportation by forklift, always use the unit base frame or the pallet supplied as

the supporting surface during transportation.

When transporting the unit using a forklift, both side of the unit must be resting on the forks.

The centre of gravity and load distribution must be taken into account.

Prepare for Installation

DANGER FROM ELECTRICAL CURRENT!

- Ensure that the intended drilling area is free from electrical cables or pipes before drilling.

PERSONAL INJURY!

- Injury may be caused by falling parts and sharp edges!
- Wear a helmet, safety boots and protective gloves when installing the unit. Ceiling installations should always be performed by two people.

NOTE!

- **You must ensure that no mechanical deformations or twisting occurs during installation of all models in all installation locations.**

Installation location

The type, condition and ambient temperature of the installation location must be suitable for the relevant fan coil unit (See Section 1.2.1 and Section 1.2.2). Consider the following points:

- Ceilings or mounting systems must be capable of bearing the weight of the unit, including all accessories.
- Install the unit only in enclosed spaces indoors.

NOTE!

- **Make all wall and ceiling openings in conjunction with an architect or stress analyst and the building contractor.**

Recommended Service space (Basic Unit Body)

In order to carry out all necessary service and maintenance work on the basic unit it is recommended that a service opening with the minimum dimensions as shown in below figure is installed in the false ceiling.

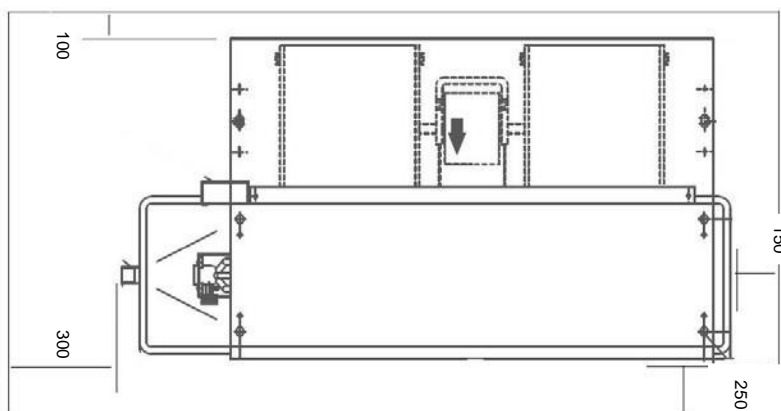

NOTE!

- Please consider that in case of further mounted accessories more or larger openings may be necessary.

Fitting space

Depending on the model and installation, the pipes may be connected from left or right. The following fitting distances of Main Unit Body should be observed for Large Air Flow & High Static Pressure type fan coil units.

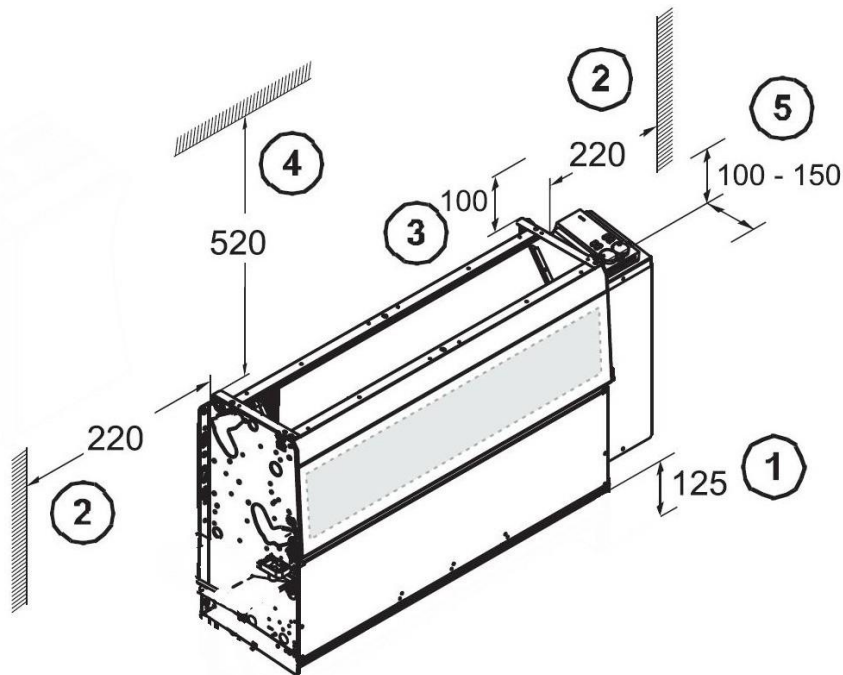

NOTE!

- Make sure there are adequate spaces reserved for installation of pipes, valves, wiring connections etc. Above indicated fitting space is for illustrative reference only and bigger fitting space should be reserved if not sure about the installation convenience or accessibility of the connections.

Unit installation

Precautions

To ensure good installation and operation, do check the following items before installation of the unit:

- Adequate space shall be provided for installation and maintenance of the unit. Please refer to Unit Dimensions and also section 4.3.2 and 4.3.3, Removable ceiling panels or accesses shall be provided for daily maintenance;
- Determine locations of pipelines and electric wires before installation; and adequate fitting space should be reserved. Kindly refer to section 4.3.3;
- Make sure hanging structure adequate to support the unit weight;
- All units shall be leveled to ensure smooth water drain and proper operation;

- e) The unit connecting air duct shall be within the external static pressure scope;
- f) Thermal insulation of chilled water valves and pipelines shall be made by the installer.

Hanging or fixing (Ceiling installation)

Please refer to dimensions in section 3.1 to know the unit external dimension, air inlet/outlet connection dimension, hanging/fixing holes dimension.

Duct connection is also possible please refer to section 4.4.3.

NOTE:

- The ceiling type fan coils can be mounted either directly under the ceiling or suspended, using appropriate means.
- In order to ensure complete removal of condensate from the condensate tray according to the hygiene regulations, cooling units are recommended to be installed with a 5 mm slope in the direction of the condensate drain and 0-2 mm in the direction of the unit front side.

Keyholes are provided at the side of the rear panel for securing the units (2 for each side). Depending on fixing type you will need suitable fixing material.

At least four drill holes are required for ceiling installation (two on each side).

- Transfer the drilling measurements to the ceiling.
- Insert the screws.
- Hang the ceiling type fan coil into the keyholes.
- Use a spirit level for precise vertical and horizontal alignment of the fan coil and tighten the screws. (Pay attention to the tilt of cooling units!)

Duct connection (ceiling concealed installation)

Air ducts made of galvanized steel sheet of certain thickness (provided by the installer) may be connected to the flanges/connections at air inlet/outlet of the unit. Refer to Unit Dimensions in section 3.1. Insert air ducts into flanges and fix with screws. If air duct and flange have different sizes, they should be connected through a site-made adapter. Connection of air supply cabinet and air duct: insert air duct into flange and fix them horizontally with screws or rivets. Same for connection of return air box.

For the ceiling concealed unit without return plenum a return air box is recommended as shown below. The air return box/duct or air outlet duct showed below which should be respected for all ceiling concealed type fan coil unit.

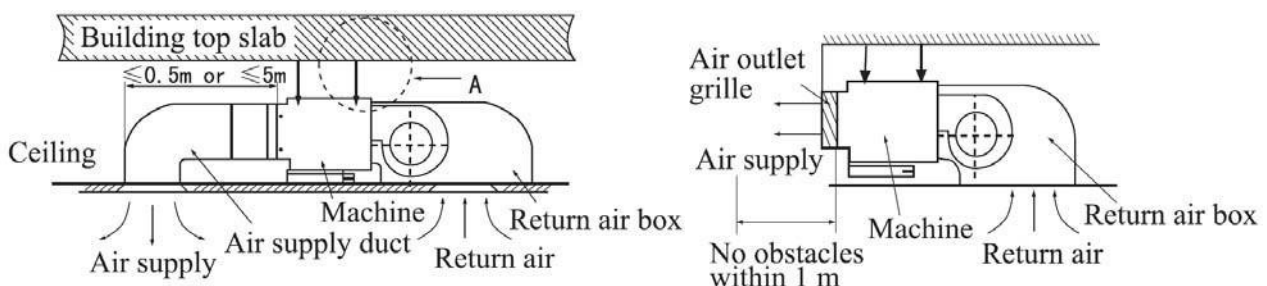

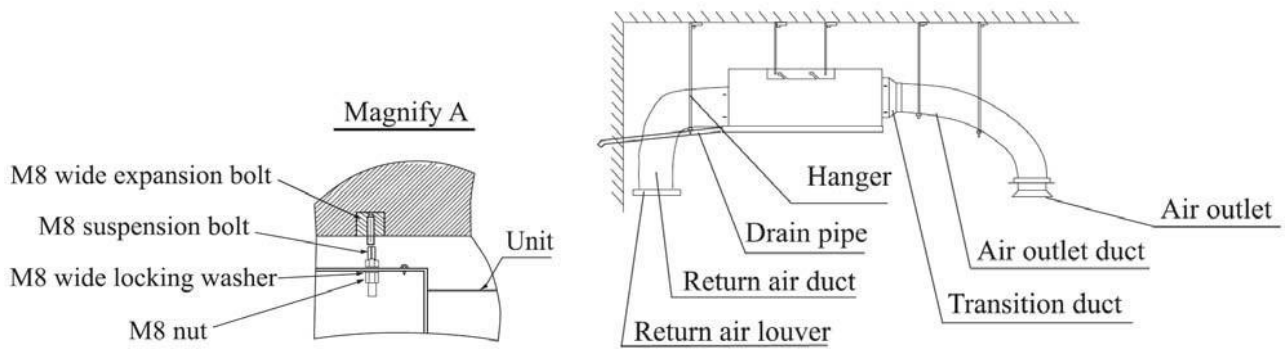

The distance from air duct outlet to fan coil outlet shall depend on actual air duct length and static pressure terminal applied.

NOTE!

- Please refer to unit model code on name plate to know the product type P1, P2 or P3,
For 3 Row Model: P1 means unit ESP 80Pa, P2 means ESP 130Pa, P3 means ESP 180Pa;
For 4 Row Model: P1 means unit ESP 60Pa, P2 means ESP 110Pa, P3 means ESP 160Pa;
- Always make sure the duct length is in accordance with the unit ESP.

Pipe connection

 DANGER OF SCALDING BY ESCAPING HEATING MEDIUM!

Before the on-site piping and the fan coil hydraulic connection is set up, the heating/cooling water should be isolated and secured against being opened unintentionally.

NOTE!

- All on-site pipes by others for the cooling medium must be insulated against condensate formation. If the pipes are run close to the lateral condensate tray, they should be isolated above the lateral condensate tray by others on-site.
- When all connections have been completed, all screw connections should be tightened and checked that they are free of mechanical stress.
- In order to ensure cleaning or disassembly of the heat exchanger according to the hygiene guidelines appropriate measures shall be taken so that medium connections at the heat exchanger could be disconnected at any time.

Valve connection

The units are supplied without valves, In case of installation with valves by others, the installation of the water inlet and outlet depends on the location of the medium/water connection and/or the used valves.

Below showed Pic. indicate the connection of a 2-way valve and 3-way valve to the units.

condensate tray.

- Note the specifications in section 2.5 to know the dimension of fittings.
- Run the pipes at a right angle to the side or to the rear.
- Seal the connections.
- Screw on the connections.

Condensate water pipe connection

In order for the condensate to be drained off properly, the condensate drain by others must be connected to the lateral condensate tray.

- Run the condensate drain at an angle/slope.
- When connecting the condensate drain to the wastewater system, observe the wastewater regulations (stench trap).

NOTE!

- **Condensate drains must always be positioned at a sufficiently steep angle! (Recommend 1:100). When running pressureless pipes or draining outdoors, no stench trap is required.**
- **The onsite condensate drain line is to be connected to the connector of the condensate tray in a stress-free way.**
- **To avoid dew formation during cooling, chilled water pipe and condensate pipe must be thermally insulated with careful treatment at insulation ends.**

NOTE!

- **After the installation, the condensate tray must be cleaned to make sure efficiency drainage.**

4.6 Electric Wiring



DANGER FROM ELECTRICAL CURRENT!

- The electricity shall be disconnected before make any installation work.
- The electrical installation of the air treatment unit must only be carried out by qualified electricians in observance of this operation manual.
- The electrical connection of fan coil units must be performed in accordance with the valid connection diagrams. The connection diagram is located on the side of the sheet electric control box.
- The earth point provided on the unit shall be connected to the grounding system of the building.
- All electric connections shall comply with local electric regulations.
- The connection diagrams do not contain any protective measures. During connection, the standards and regulations currently in force must be observed and cleared with the local electricity company.



DAMAGE TO THE UNIT!

- **Wrong wiring connection may cause permanent damage to fan motors**
- **Make wiring according to the indication on the wiring diagram sticked on the back of elec. box.**

NOTE!

- **Please make the correct wiring of motorized 2-way or 3-way valve and thermostats in according to its installation instructions and make correct linkage between the units.**

3. Commissioning

ELECTRICAL HAZARD!

Before carrying out any work on the unit, power the unit down to avoid injury from electrical current. Check that the unit is isolated and ensure that the appropriate point of the unit for the on-site power supply is secured against being switched back on.

DANGER OF SCALDING!

Before performing work on the valves or the inlet or outlet pipes, seal off the heating or cooling medium inlet to prevent scalding. Do not commence work before the heating medium has cooled down.

DANGER OF ROTATING UNIT PARTS!

Rotating fan wheels can cause injury! Before performing any work on the unit, ensure that it is powered down. Ensure that the appropriate point of the unit for the on-site power supply is secured against being switched back on.

Requirements for commissioning

After installation, the installers shall re-inspect and confirm the following items have been made. This manual has been carefully read through. Operators are generally familiar with the unit and can operate it.

- The fan coil is electrically isolated.
- The entire fan coil system has been installed both mechanically and electrically.
- Air ducts have been completely connected and firmly installed;
- All medium/water pipes have been rinsed and are free from residues and foreign objects.
- The system is properly pressurized (Recommended test pressure 2.4Mpa and more than 10min) and then filled with clean medium/water.
- Check that the fan coil is properly fixed and mounted (on the wall, ceiling or on the floor).
- Manually check if valves, actuators thermostats are secured according to its operation manual.
- Tighten all medium/water screw connections.
- Check all electric connections using current wiring diagrams and check terminal strip screws for correct tight seat.

NOTE!

Before commissioning, ensure that

- **the unit discharge (heat exchanger),**
- **the condensate trays and the condensate pump intake area**
- **and the filter medium are clean.**

If necessary, these components may have to be cleaned or the filter medium changed.

NOTE!

- **For first water filling, the fan coil pipeline may retain some air, which will be finally entrapped at top of the water system. A manual discharge valve is provided at the water**

outlet joint of the water system. When abnormal noise is heard due to residual air in the water system or coil, turn the discharge valve knob to release the air. If the knob is too tight, you may use a pair of pinchers to turn it anticlockwise until water flows out of the valve steadily, and then tighten the knob again.

Startup

The fan coil usually is controlled by a thermostat which can on/off the unit, change the fan speed and also the water valve.

Switch on the power and follow the operation indication of the thermostat to operate the unit one by one working in high/mid/low speed.

Adjust the air outlet grill, setting fan speed and water flow to reach best cooling/heating effect.

In case of abnormal noise or behavior, switch off the unit and recheck the previous mentioned items. Otherwise it is recommended to set the unit working in high speed for 24 hours and recheck the unit behavior again.

NOTE!

- **After the commissioning, in case of non-use in winter season, water inside the unit shall be drained to avoid pipe cracks due to ice formulation.**

4. Maintenance and Troubleshooting

ELECTRICAL HAZARD!

Before carrying out any work on the unit, power the unit down to avoid injury from electrical current. Check that the unit is isolated and ensure that the appropriate point of the unit for the on-site power supply is secured against being switched back on.

DANGER OF SCALDING!

Before performing work on the valves or the inlet or outlet pipes, seal off the heating or cooling medium inlet to prevent scalding. Do not commence work before the heating medium has cooled down.

DANGER OF ROTATING UNIT PARTS!

Rotating fan wheels can cause injury! Before performing any work on the unit, ensure that it is powered down. Ensure that the appropriate point of the unit for the on-site power supply is secured against being switched back on.

Maintenance

The Large Air Flow & High Static Pressure fan coil unit is a high-quality and reliable unit. However, to guarantee the permanent functioning and performance of the unit, regular maintenance and inspection by technical experts is necessary.

NOTE!

- **Maintenance may only be performed by trained technical personnel in observance of this operation manual and current regulations.**
- **The manufacturer's warranty will be invalidated if unit damage is attributed to the failure to perform regular maintenance and inspections.**
- **The valid warranty prescribes to maintain a written maintenance report according to the following table.**

Checklist of Periodic Maintenance

The following is a suggested maintenance plan.

Monthly Check

If the drip tray is clean and if condensate can flow to the drain pipe freely.

Yearly Check

- a) Check if the unit casing is corroded. Clean and repair it if necessary;
- b) Check if the fan blades and volute are damaged. Manually turn the blades to make sure it rotates freely without obstacles;
- c) Check if coil fins are too dirty or damaged;
- d) Clean and tighten all electric wirings;
- e) Drain chilled water of all the system to make descaling and water replacement

NOTE!

- **Untreated water may cause unit scaling, corrosion and deterioration. System testing and maintenance shall be guided by water treatment experts. The manufactory shall not be held liable for any losses due to poor water quality.**
- **Due to limitation of support weight and dimensions, this job shall be collaborated by two installers to ensure safety.**
- **During off period in winter, water inside the unit shall be drained to avoid pipe cracks due to ice formulation.**

Coil Cleaning

Blocked or contaminated coil may decrease cooling capacity. It is recommended to clean it every 3 month in the following steps. It is also recommended to read section 2.3 before going to following steps.

1. Disconnect the power and motor wiring to stop rotation of fan blades;
2. Un-tighten fixing screws between side panel and drip tray;
3. Separate the casing and trip tray. Un-tighten fixing screws between fixing plate and side panel;
4. Draw out the coil evaporator;
5. Clean the coil and remove the scale;
6. Re-install the coil evaporator and drip tray, and fix them with screws;
7. Connect the power and water supply. Make trial operation to see the effect.

Drip tray

For smooth draining of condensate, the drip tray must keep clean, otherwise immediate cleaning must be made.

Troubleshooting

Deviations from normal operating states of the fan coil units are evidence of malfunctions that must be investigated by maintenance personnel.

The following table should serve as a starting point for maintenance personnel regarding possible causes of trouble and their correction.

Fault	Possible causes	Remedy	M	
Fan does not work	Unit not switched on	Switch on unit		
	No electrical voltage	Check fuse/power supply	*	
	Electrical cables not connected	Connect electrical cables	*	
	Unit fuses defective	Replace fuses	*	
Unit too noisy	Too high RPM level switched on	Set a lower RPM level		
	Air intake or discharge areas blocked	Clear discharge/air intake of obstructions or kinks		
	Noisy fan bearings	Replace the faulty fan	*	
	Filter is dirty	Clean/replace the filter		
Unit does not cool(heat) or cool (heat) insufficiently	Fan not switched on	Switch on the fan		
	Air volume flow of the unit too low	Select a higher RPM level		
	Air intake or discharge areas blocked	Unobstruct or clean airways		
	Fan blocked/faulty	Check fan, replace if necessary	*	
	Filter is dirty	Clean/replace the filter		
	Water flow rate too low	Check pump performance, Check pipe run balance and adjust using calculated pressure loss	*	
	Cooling medium is not cold	Switch on chilled water set, Switch on the circulating pump, Bleed the system		
Heating medium is not hot	Switch on the heating system boiler, Switch on the circulating pump, Bleed the system			
Water leakage in unit area	Main condensate tray drain blocked	Clean the main condensate tray and the condensate drain		
	Side wall-mounted/ceiling-mounted condensate tray drain blocked	Clean condensate drain and check for sufficient gradient, then clean and fill the siphon if necessary	*	
	Chilled water pipes not correctly insulated	Insulate the chilled water pipes	*	
	Unit not positioned horizontally	Align the unit and position it horizontally	*	
	Heat exchanger or hydraulic connections leaking	Check the heat exchanger, bleeding and valve connections for leaks		
		If necessary, retighten connections, clean screw insert or reseal the connections		
		On valves, check the screw connections for ease of movement, clean sealing surfaces and replace seal if necessary		*
Check the soldered joints between the collector and heat exchanger tubes and on the heat exchanger deflection bends for leaks; if leaking, replace the heat exchanger			*	

*Items marked with * can only be performed by technical person only.

Making Extra Good Air!



Respect the environment!

For a correct disposal, the different materials must be divided and collected according to the regulations in force.